

Final Project Report

Investigating the Contributing Factors to Willingness to Share Automated Vehicles with Gender Focus

Prepared for Teaching Old Models New Tricks (TOMNET) Transportation Center



By

Sara Khoeini

Email: skhoeini@asu.edu

Ram M. Pendyala

Email: ram.pendyala.@asu.edu

Denise S. Baker

Email: denise.silva@asu.edu

Deborah Salon

Email: dsalon@asu.edu

School of Sustainable Engineering and the Built Environment
Arizona State University
660 S. College Avenue, Tempe, AZ 85287-3005

September, 2022

TECHNICAL REPORT DOCUMENTATION PAGE

1. Report No. N/A	2. Government Accession No. N/A	3. Recipient's Catalog No. N/A	
4. Title and Subtitle Investigating the Contributing Factors to Willingness to Share Automated Vehicles with Gender Focus		5. Report Date September 2022	
		6. Performing Organization Code N/A	
7. Author(s) Sara Khoeini, https://orcid.org/0000-0001-5394-6287 Ram M. Pendyala, https://orcid.org/0000-0002-1552-9447 Denise S. Baker, https://orcid.org/0000-0003-1414-8439 Deborah Salon, https://orcid.org/0000-0002-2240-8408		8. Performing Organization Report No. N/A	
		9. Performing Organization Name and Address School of Sustainable Engineering and the Built Environment Arizona State University 660 S. College Avenue, Tempe, AZ 85287-3005	
11. Contract or Grant No. 69A3551747116			
12. Sponsoring Agency Name and Address U.S. Department of Transportation, University Transportation Centers Program, 1200 New Jersey Ave, SE, Washington, DC 20590		13. Type of Report and Period Covered Research Report (2020-2021)	
		14. Sponsoring Agency Code USDOT OST-R	
15. Supplementary Notes N/A			
16. Abstract This study uses a survey collected in four metropolitan areas in the United States (Phoenix, Atlanta, Austin, and Tampa) to understand the attitudinal factors underlying men and women's willingness to share rides on ridehailing services that use automated vehicles. The study uses a measurement model to classify the attitudinal measures into unobserved latent constructs, and preferences towards owning and driving a vehicle. A Structural Equation Model is then used to measure the effects of gender upon the willingness to share rides in autonomous vehicles, controlling for respondents' attitudes (latent constructs), current use of mobility-on-demand services, and socioeconomic characteristics. The results of this study are key to ensure that the future of transportation reaches all, regardless of gender. Understanding women's willingness to engage in autonomous shared rides will enlighten the process of including them in the automated, shared, and electric future. By identifying the different attitudinal traits motivating different groups to engage in shared ridehailing rides, ridehailing service providers can better accommodate their needs, and promote a more egalitarian transportation service. Preliminary results indicate that men's environmental motivations to use AV shared rides are stronger than women's, while women's perception of autonomous vehicles is a stronger predictor of AV ridesharing adoption.			
17. Key Words Measuring Attitudes, Survey Methodology, Survey Weighting, Survey Instrument, Sampling Method, Measuring Behaviors		18. Distribution Statement No restrictions.	
19. Security Classif.(of this report) Unclassified	20. Security Classif.(of this page) Unclassified	21. No. of Pages 51	22. Price N/A

Form DOT F 1700.7 (8-72)

Reproduction of completed page authorized

DISCLAIMER

The contents of this report reflect the views of the authors, who are responsible for the facts and the accuracy of the information presented herein. This document is disseminated in the interest of information exchange. The report is funded, partially or entirely, by a grant from the U.S. Department of Transportation's University Transportation Centers Program. However, the U.S. Government assumes no liability for the contents or use thereof.

ACKNOWLEDGMENTS

This project was funded by a grant from A USDOT Tier 1 University Transportation Center, supported by USDOT through the University Transportation Centers program. The authors would like to thank the TOMNET and USDOT for their support of university-based research in transportation, and especially for the funding provided in support of this project.

TABLE OF CONTENTS

EXECUTIVE SUMMARY	6
INTRODUCTION	7
DATA	9
METHODS	11
Decision Trees	11
Multi-Group Structural Equation Model	14
RESULTS	16
Descriptive Analysis	16
Decision Tree Analysis	31
Multi-Group Structural Equation Model	33
CONCLUSIONS AND POLICY IMPLICATIONS	42
REFERENCES	44

LIST OF TABLES

Table 1 Sample Description - Person and Household Attributes for Men’s and Women’s Samples	10
Table 2 Parameter Specification for Growing Decision Tree to Explore Willingness to Share Rides in Autonomous Vehicles	13
Table 3 Willingness to Share Rides in Autonomous Vehicles for Different Socio-demographic and Attitudinal Groups (Weighted)	17
Table 4 Gender Differences in Travel Behavior (Weighted).....	20
Table 5 Average Monthly Expenditure on Ridehailing Services, by Gender (Weighted)	22
Table 6 Description of the Last Ridehailing Trip, by Gender and Service Type (Weighted)	24
Table 7 Gender Differences in Familiarity with Autonomous Vehicles, Willingness to Pay, Buy, and Increase Commute Time (Weighted)	27
Table 8 Gender Differences in Willingness to Share for Different Market Segments (Weighted)	30
Table 9 Full Model Results For Two-Group and One Group Solution Investigating Willingness to Share Rides in Autonomous Vehicles.....	34
Table 10 Total Effects Table for the Willingness to Share Rides in Autonomous Vehicles.....	41
Table 11 Goodness of Fit of Models Exploring Willingness to Use Shared Autonomous Ridehailing.....	42

LIST OF FIGURES

Figure 1 Proposed Model Framework for the Investigation of Women's Willingness to Share Rides in Autonomous Vehicles.....	15
Figure 2 Service Type Chosen in the Last Ridehailing Trip, by Gender and Companionship (Weighted)	23
Figure 3 Gender Differences on Attitudes Towards Ridehailing Services (Weighted).....	25
Figure 4 Gender Differences in General Attitudes (Weighted)	26
Figure 5 Gender Differences on Attitude Towards Autonomous Vehicles (Weighted).....	27
Figure 6 Expected Activity Engagement During AV Rides, by Gender (Weighted).....	28
Figure 7 Decision Tree Result for Exploring Willingness to Share Rides in an Autonomous Vehicle Ridehailing Service	32
Figure 8 Variable Importance for Growing Decision Tree Exploring Willingness to Share Rides in AV Ridehailing Trips.....	33
Figure 9 Measurement Model Results of the Willingness to Share Rides in Autonomous Vehicles (Unstandardized Results)	37
Figure 10 Illustration of the Relationships between Exogenous and Endogenous Variables on Willingness to Share Rides in Autonomous Vehicles Model	39
Figure 11 Structural Relationship between Endogenous Variables on Willingness to Share AVs Model (Unstandardized)	40
Figure 12 Structural Relationship between Endogenous Variables on Willingness to Share AVs Model (STDYX)	40

EXECUTIVE SUMMARY

This study uses a survey collected in four metropolitan areas in the United States (Phoenix, Atlanta, Austin, and Tampa) to understand the attitudinal factors underlying men and women's willingness to share rides on ridehailing services that use automated vehicles. The study uses a measurement model to classify the attitudinal measures into unobserved latent constructs, and preferences towards owning and driving a vehicle. A Structural Equation Model is then used to measure the effects of gender upon the willingness to share rides in autonomous vehicles, controlling for respondents' attitudes (latent constructs), current use of mobility-on-demand services, and socioeconomic characteristics. The results of this study are key to ensure that the future of transportation reaches all, regardless of gender. Understanding women's willingness to engage in autonomous shared rides will enlighten the process of including them in the automated, shared, and electric future. By identifying the different attitudinal traits motivating different groups to engage in shared ridehailing rides, ridehailing service providers can better accommodate their needs, and promote a more egalitarian transportation service. Preliminary results indicate that men's environmental motivations to use AV shared rides are stronger than women's, while women's perception of autonomous vehicles is a stronger predictor of AV ridesharing adoption.

INTRODUCTION

Consumers' interest in adopting autonomous vehicles in a shared form has been studied in the past. One of the ways that willingness to share AVs can be investigated is through the willingness to use carsharing services. Lavieri et al. (2017) identified that AV sharing was positively correlated with owning fewer vehicles, living in high-density neighborhoods, and previous experience with carsharing and ridesharing. Lavieri et al. (2017) also suggest that enhancing neighborhood densification would be an effective way to move AV adoption toward a sharing model. A Korean study shows that people who chose shared services often did so because they wanted to experience AVs before purchasing one and suggests that investing in psychological ownership (e.g., feeling that the AV is yours and customized to you) could be a good strategic approach to market shared AVs (Lee, Lee, Park, Lee, & Ha, 2019). In the Netherlands, Winter et al. (2017) identified that early adopters showed a preference towards shared AVs in comparison to free-floating car sharing. Regular and late adopters showed aversion to shared AVs (Winter, Cats, Martens, & Van Arem, 2017). In Germany, Pakush et al. (2018) found that 59 percent of study participants prefer fully automated carsharing to traditional carsharing; and 47 percent prefer public transport to autonomous carsharing. Pakush et al. (2018) also highlight that private ownership would still be the preferred mode in a future with automated mobility, and only a minority of respondents would shift from other modes to sharing, mainly shifting from public transportation. A Canadian study identified that private AVs are more likely to be adopted by individuals who own cars costing more than \$30,000, and shared autonomous vehicles were more likely to be adopted by occasional teleworkers, transit, and non-motorized commuters (Laidlaw & Sweet, 2018).

Willingness to share pooled rides, the main interest of this research, has also been explored in scholarly articles. Narayanan et al. (2020) performed an extensive literature review analyzing previous studies regarding shared autonomous vehicles, in terms of traffic safety, travel behavior, economy, transport supply, land use, environment, and governance. Narayanan et al. (2020) identified several factors affecting willingness to share, namely safety concerns, increased travel time, the cost difference between private ride and pooled option, and socioeconomic attributes – wealthier, highly educated, young, living close to downtown are more likely to share. Lavieri and Bhat (2019) found that the main elements driving willingness to share rides are acceptance of increased travel time (due to picking up and dropping off other passengers), and approval of unfamiliar individuals inside the vehicle during the trip. Lavieri and Bhat (2019) also identified that, in an automated future, increased travel time would be a greater barrier in comparison to additional travelers, when it comes to willingness to pool rides. Pettigrew et al. (2019) identified that around 20 percent of their studied sample were interested in ridesharing, those being individuals with high expectations of positive outcomes from AVs, and relatively low levels of concern. Krueger et al. (2016) highlight that service attributes (e.g., cost, travel, and waiting times) may be critical determinants of the use of shared AVs and dynamic ridesharing. Krueger et al. (2016) also mention that being multimodal increases the chance of choosing a shared service, and individuals 24 to 29 years old are also more likely to choose shared AV with dynamic ridesourcing. Nazari et al. (2018) found that those who cover greater distances in a day are less likely to adopt AVs, both in private and shared forms.

Commute trips were also of great interest in previous studies about shared rides in autonomous vehicles. Lavieri and Bhat (2019) found that women and young adults are less likely to pool rides for commuting purposes, but neither age nor gender influenced their decision to share leisure trips. Nielsen and Haustein (2018) reported that, for all the attitudinal groups they identified, it would be more attractive to drive to work alone in a self-driving car than to drive together with

others, and found ownership more interesting when compared to shared use. Nazari et al. (2018) identified that full-time employees show a preference towards commuting with AVs in both forms, whereas self-employed individuals preferred the carpooling option. Night-shift commuters were less likely to be interested in ridesharing with autonomous vehicles at all, and commuters who live in neighborhoods with higher land-use mix diversity were more likely to share rides in commuting trips (Nazari, Noruzoliaee, & Mohammadian, 2018).

This study needs to highlight that the relationship between ridehailing usage and the adoption of automated mobility has been identified in the past. Sener and Zmud (2019) investigated the role of ridehailing on willingness to adopt autonomous vehicles and found that those who currently use ridehailing are more likely to use AVs as a mobility service, in comparison to non-users. Sener and Zmud (2019) also report that willingness to adopt autonomous vehicles depended on demographics, residential location, technology, and shared mobility use, as well as attitudes and perceptions. In their study, Sener and Zmud (2019) identified that most respondents expect to use autonomous vehicles in more than one form, such as a mix of ridehailing services and vehicle ownership. People who intended to use AV ridehailing would also be less likely to use it as ridesharing, except for low-income individuals who were more likely to adopt the pooled version (Sener & Zmud, 2019). Geographically, Phoenix residents were the least likely to adopt ridesharing, despite being enthusiastic about using autonomous vehicles (Sener & Zmud, 2019). Importantly, Sener and Zmud (2019) identified gender differences as well, suggesting that women were less likely to use autonomous vehicles, both as a ridehailing service and as a privately-owned vehicle.

Gender issues in transportation are not a new concern and have been identified long before autonomous vehicles became a popular topic. Blumberg (2004) recognized that policy planners focus on long commutes as the most common behavior, even though women, especially those of low income, have very different travel patterns. The differences in travel patterns can be explained by several reasons, for example, due to household obligations with childcare and maintenance, women are more likely to have shorter commutes, and high rates of trip chaining (Blumberg, 2004). Blumberg (2004) also highlights that an important aspect of moving women is recognizing that they view private vehicles as a safe way to travel, especially off-peak hours and after dark, and concern for personal security is often part of mode choice among women (Blumberg, 2004). In Portugal, Beirão & Sarsfield Cabral (2008) corroborates that when reporting that men and women have different travel behavior and different attitudes towards public transportation; men showed a significantly higher need for control, and were more car-dependent, in comparison to women, while women were more sensitive to travel costs, and travel-related stress. In Spain, Maciejewska et al. (2019) identified that the gender gap on mobility levels is particularly evident among older individuals, elderly women being the highest immobile social group. Maciejewska et al. (2019) also identified that women reported using sustainable modes more frequently than men (Maciejewska, Marquet, & Miralles-Guasch, 2019). Stark and Meschik (2018) highlight that not only personal security is perceived differently by men and women, but personal security perception also plays different roles in shaping men and women's travel. In Brazil, Capasso da Silva and Rodrigues da Silva (2020) identified that women felt less safe against crimes and that perception impacted the likelihood of using non-motorized trips to the local university.

Despite growing efforts to bridge the gender gap in transportation, recent mobility solutions are not exempt from gender biases. Priya Uteng (2019) identified evidence that even relatively newer forms of mobility, such as carsharing and bike-sharing, still show gender differences in their use patterns. Priya Uteng (2019) highlights that smart mobility does not automatically create

inclusive cities, which creates the need for understanding women's needs and preferences, as they must be included in the planning of smart cities. Priya Uteng (2019) also notes that to be gender-responsive, planning must account for the role that transportation plays in women's employment and lifestyle. Del Mar Alonso-Almeida (2019) found that women's use of carsharing was hindered by perceived personal and business values of using the service. Women's perceptions of peer-to-peer carsharing (such as Turo) and car-club carsharing (such as Zipcar) were not the same, and they impacted women's willingness to use each service (Del Mar Alonso-Almeida, 2019). In particular, del Mar Alonso-Almeida (2019) highlights that women preferred to avoid the stress associated with traveling with unfamiliar passengers, possibly due to fears for their security. Also regarding carsharing, Böcker and Meelen (2017) identified that environmental preferences are a stronger motivation to adopt the service for women, in comparison to men.

The fact the women seem less interested in autonomous vehicles has been widely acknowledged (Nazari, Noruzoliaee, & Mohammadian, 2018; Hulse, Xie, & Galea, 2018; Lavieri, et al., 2017; Lee & Mirman, 2018; Hohenberger, Spörrle, & Welp, 2016; Clifton & Dill, 2005). Even though there's evidence that women's travel patterns might be more efficient for the operation of shared autonomous vehicle fleets (Broaddus, 2019). In Germany, Hohenberger et al. (2016) studied the differences between men and women regarding their willingness to use AVs. Hohenberger et al. (2016) suggest that anxiety-related responses towards AVs should be addressed with a focus on the pleasurable outcomes of automated mobility to reduce differences between genders regarding willingness to adopt autonomous vehicles. Siripanich (2018) noted that even though the use of ridehailing services among women is widely spread, many concerns still permeate women's perceptions of such services. Siripanich (2018) highlights the need to promote inclusive design when planning automated ridehailing services, to account for women's perceptions and concerns, and proposes rethinking what safety would look like when a driver is no longer present, providing safe and discrete strategies to terminate a ride that makes a passenger uncomfortable, understanding that social contexts are unique and they differ in their safety requirements, as well as data transparency.

Women face many challenges on transportation that are real and current – such as sexual harassment and lack of personal security on public transit. If not accounted for, women's challenges will linger into the new mobility future that is being shaped. Those who are willing to engage in shared ridehailing rides are a heterogenous group and should be studied like so. Different socio-demographic groups are sensitive to different aspects of automated mobility, and ridehailing service providers must account for that when planning an equalitarian sharing service. Despite the extensive literature on willingness to adopt shared rides, the extent to which men's and women's attitudes influence it has been under-explored. Thus, the present study aims at contributing to the growing body of literature by exploring how women's willingness to share automated vehicles is shaped by attitudes. Such understanding is key to ensure ridehailing providers accommodate the different transportation needs of women and pave the path for a more egalitarian transportation service.

DATA

The investigation of the effects of attitudes on willingness to share autonomous vehicles was performed using the TOMNET D-Stop Transformative Technologies in Transportation T4 full deployment survey (Khoeni, et al., 2019).

A subsample of the pooled data (Phoenix, Atlanta, Tampa, and Austin) was selected so there would be no missing records on any of the variables of interest. Of those 2,984 selected

responses, 42.4 percent self-declared as men, and 57.6 percent self-declared as women. Although individuals who do not identify themselves as male nor female are a key piece of achieving gender equality, the size of the sample collected for that group did not support meaningful statistical analysis. Thus, due to the limited sample size of other gender categories, only those who self-identified as men or women were included. Further studies should expand the current analysis to include non-binary individuals. The sample used in this manuscript (N=2,984) is described in Table 1.

Regarding socio-demographic attributes (Table 1), the only two distributions that were not statistically different were driver licensure and the presence of children in the household. The female sample is younger, has fewer college degree holders, more individuals that are both a worker and a student, and more people living alone when compared to the male sample. Women also reported driving less and more frequently being part of households with lower income, and that are not homeowners.

Table 1 *Sample Description - Person and Household Attributes for Men and Women Samples*

	Men (N=1264)	Women (N=1720)
Age***		
18-30 years	16.90%	28.00%
31-40 years	10.00%	12.80%
41-50 years	13.60%	17.30%
51-60 years	16.50%	17.30%
61-70 years	20.10%	14.20%
71+ years	22.90%	10.30%
Highest education attained***		
Some grade/high school	1.80%	0.90%
Completed high school or GED	7.80%	7.00%
Some college or technical school	25.80%	31.70%
Bachelor's or some graduate school	37.30%	36.40%
Completed graduate degree(s)	27.30%	24.10%
Employment status***		
A worker (part-time or full-time)	53.20%	53.50%
Both a worker and a student	7.00%	12.50%
A student (part-time or full-time)	7.50%	9.50%
Neither a worker nor a student	32.30%	24.50%
Race***		
White or Caucasian	80.90%	74.50%
Black or African American	6.00%	10.20%
Native American	0.50%	0.60%
Asian or Pacific Islander	7.90%	9.00%
Other	1.90%	1.40%
Multi race	2.80%	4.20%
Driver's licensure		
Do not have a driver's license	6.10%	6.30%
Has a driver's license	93.90%	93.70%
Average miles driven in a regular week***		
Zero	6.30%	7.90%
1-25 miles	13.10%	19.80%
26-50 miles	15.70%	20.50%
51-75 miles	13.40%	12.50%
76-100 miles	12.40%	11.80%
101-200 miles	20.90%	14.80%
201-300 miles	12.00%	8.10%
301-500 miles	5.50%	3.80%

	Men (N=1264)	Women (N=1720)
More than 500 miles	0.70%	0.80%
Household size***		
1 - Live alone	18.30%	23.80%
2	46.20%	34.80%
3	12.30%	15.50%
4 or more people	23.20%	25.90%
Household vehicles***		
0 - No vehicle	2.80%	3.90%
1 vehicle	20.20%	28.00%
2 vehicles	43.00%	38.50%
3 vehicles or more	34.10%	29.60%
Household income***		
Less than \$25,000	6.60%	11.80%
\$25,000 to \$49,999	13.60%	17.00%
\$50,000 to \$99,999	32.50%	35.30%
\$100,000 to \$149,999	26.70%	19.80%
\$150,000 to \$249,999	13.20%	11.30%
\$250,000 or more	7.30%	4.80%
Children in the household		
0 - No children	83.50%	81.80%
1 child	7.80%	8.70%
2 or more children	8.70%	9.50%
Tenure status***		
Not homeowner	23.70%	35.80%
Homeowner	76.30%	64.20%

*** Distributions are significantly different among the response groups at a 5% confidence level.

METHODS

To better understand the effects of gender on willingness to share rides in AV ridehailing trips, this dissertation investigates the issue through two different methods. First, a decision tree analysis was performed to investigate the importance of gender in the stated intention of sharing rides in AV ridehailing. Then a Structural Equation Model is estimated to better understand what motivates women to share AVs. Understanding how the factors underlying their decision differ (by estimating separate models) can provide insights on how to reach out to women to ensure they are included in the future of mobility. The two methods fundamentally offer unique insights and angles, that together paint a more holistic picture of willingness to share.

Decision Trees

Decision Trees (DT) are a non-parametric supervised machine learning technique. It can also be defined as a classification model inducted in a tree-structure format (Fürnkranz, 2011; Kingsford & Salzberg, 2008). Decision Trees can be used for a wide variety of purposes, such as classifying, segmenting, and identifying interactions within a dataset. In this dissertation, DTs are used to classify willingness to share rides in autonomous vehicles, as well as to identify sub-groups of the population who are willing to use such a service. In particular, this exercise aims at identifying the impact of gender on such classification.

Decision trees can be grown using different algorithms, which should be chosen based on the analysis's purpose. For this dissertation's analysis, the Classification and Regression Trees algorithm first proposed by Breiman et al. (1984) is used through the SPSS Decision Tree tool (IBM Corp., 2017). This algorithm's goal is to split the sample into segments that are as homogenous as possible regarding the dependent variable, in this case, willingness to share rides

in an AV ridehailing trip. The CART algorithm begins splitting the root node (the entire learning sample) in two and continues dividing the result nodes until reaching a stopping criterion. The following equations and methods show the formulation used by SPSS software as described in their algorithms and decision tree documentation (IBM Corp., 2017).

The splitting rule selected for the DT application in this study is a minimum improvement of 0.0001 on the Gini index. The Gini impurity measurement is defined as the probability of incorrectly labeling a random observation by doing so based on the observed distribution (Daniya, Geetha, & Suresh Kumar, 2020). It is calculated in SPSS (2017) using Equation (1):

$$i(t) = \sum_{i,j} C(i|j) p(i|t) p(j|t) \quad (1)$$

where

t is the node in question,

j and i are classes of the dependent variable,

$i(t)$ is the Gini index of node t ,

$C(i|j)$ is the cost of misclassifying a class j case as a class i case,

$p(i|t)$ is the probability of a case in class i , given it belongs to node t , and

$p(j|t)$ is the probability of a case in class j , given it belongs to node t .

The quality of the split is then determined based on how the split nodes perform compared to the parent node. The improvement, defined in SPSS (2017) as shown in Equation (2), is the performance measure that needs to be maximized, and the splitting rule sets the minimum acceptable improvement to justify the split.

$$\Delta i(s, t) = i(t) - p_L i(t_L) - p_R i(t_R) \quad (2)$$

where

$\Delta i(s, t)$ is the Gini splitting criterion,

$i(t)$ is the Gini index of node t calculated as Equation (1),

p_L is the probability of sending a case to the left node t_L , as Equation (3)

p_R is the probability of sending a case to right node t_R , as Equation (4), and

$p(t)$ is the probability of a case in node t .

$$p_L = \frac{p(t_L)}{p(t)} \quad (3)$$

$$p_R = \frac{p(t_R)}{p(t)} \quad (4)$$

One of the advantages of using the CART algorithm in the SPSS tool (IBM Corp., 2017) is the possibility of using surrogate measures for predictor variables. Whenever a missing case needs to be assigned in a split, other independent variables that are highly associated with the main variable used on the split are used as surrogate measures. Even though it is possible to specify the maximum number of surrogates, this study uses the default option, where any other predictor

variable can serve as surrogates for the variable used on the split (IBM Corp., 2017). An implication of using surrogates in estimating the tree is that even if a variable does not serve as a node splitter it still contributes to tree growth.

The estimation of any decision tree requires the definition of stopping rules to determine when a node should no longer be divided. Without any intervention, the tree would continue to grow until all the end nodes are perfectly homogenous, meaning all the cases belong to one category. However, that could lead to an overfitted model, which is undesired, thus stopping criteria must be specified. For the purposes of this study, a maximum of 5 levels was specified, as well as a minimum of 100 cases for a parent node, and a minimum of 50 cases for a child node. Additionally, if the split using the selected independent variables provide an improvement smaller than the user-specified limit (in this case a change of 0.0001 in the Gini measurement), the node will not be split.

Cross-validation of the learning process was employed to validate the results obtained. This procedure divides the original sample into n random subsamples called folds. For each fold i , a tree is grown using the $n-1$ folds excluding the i^{th} fold, and its risk is estimated using the i^{th} excluded sample. This procedure returns one final tree, in which risk is obtained as the average of the n calculated risks (IBM Corp., 2017). In order to cross-validate the estimation pruning cannot be applied to the model. The tree grown for this dissertation uses 25 folds, the maximum allowed by the software.

The summary of the specifications used to grow the tree used in this study is described in Table 2.

Table 2 *Parameter Specification for Growing Decision Tree to Explore Willingness to Share Rides in Autonomous Vehicles*

Parameter	Specification
Growing algorithm	CART, weighted
Maximum number of levels	5
Minimum parent node size	100 (4% of sample size)
Minimum child node size	50 (2% of sample size)
Impurity measure	Gini
Minimum change in improvement	0.0001 (Splitting rule)
Pruning	No pruning, to allow for folding cross-validation
Cross-validation	25 folds
Dependent variable	Agreement with the statement “I will use AV ridehailing services with other passengers I don’t know”: 1 – Strongly agree or Agree 0 – Neutral, Disagree, or Strongly disagree
Independent variables	<ul style="list-style-type: none"> - Gender (men, women) - Age (61 and older, 60 and younger) - Ridehailing usage (user, not user) - Annual household oncome (\$150,000 and above, less than \$150,000) - Commute (commuter, non-commuter) - Education (bachelor’s degree or higher, no bachelor’s degree) - Presence of children (present, not present) - Race (White, non-White) - Population density of the home address census tract (Unit: person/sq mile, Geography: Census tract, Source: 2017 Census LEHD) - Agreement to statements (Agree/Strongly agree, Neutral/Disagree/Strongly disagree)

Parameter	Specification
	<ul style="list-style-type: none"> - “When traveling in a vehicle I prefer to be a driver rather than a passenger.” - “Learning how to use new technologies is often frustrating for me.” - “I am committed to using a less polluting means of transportation (e.g., walking, biking, and public transit) as much as possible.” - “I feel uncomfortable around people I do not know.” - “I am too busy to do many of the things I like to do.” - “Public transit is a reliable means of transportation for my daily travel needs.” - “I definitely like the idea of owning my own car.”

Risk estimates were used to measure the tree’s predictive accuracy and the overall model performance. For categorical dependent variables, such as the willingness to share rides in AV ridehailing trips, the risk is estimated as the proportion of misclassified cases. Therefore, lower risk estimates mean better models.

The CART algorithm provisions the calculation of the importance of each independent variable in the determination of the final tree. SPSS defines the Measure of Importance $M(X)$ of a predictor variable X as the (weighted) sum of all splits in the tree where X has been used either as a primary or surrogate splitter. The formulation provided in the software documentation is shown here as Equation (5). The variable importance, however, is expressed in relation to the variable with the highest Measurement of Importance. Equation (6) shows the computation for the Variable Importance so it ranges from zero to 100, 100 representing the independent variable with the highest Measurement of Importance (IBM Corp., 2017).

$$M(X) = \sum_{t \in T} \Delta(\tilde{s}_X, t) \quad (5)$$

$$VI(X) = \frac{M(X)}{\max_X M(X)} \times 100 \quad (6)$$

where

t is a node in the tree with T nodes,

$M(x)$ is the measurement of the importance of the predictor X to the final tree T ,

\tilde{s}_X is the split with maximized probability, and

$VI(X)$ is the variable importance of X .

Multi-Group Structural Equation Model

As identified previously, Structural Equations Models are a powerful tool for exploring the relationships between attitudes and travel behavior (Golob, 2003). Therefore, this study will investigate perceptions of autonomous vehicles and perceived safety using a Structural Equation Model, similar to the framework detailed in the previous chapter.

In this particular case study, willingness to share ridehailing rides in an autonomous vehicle was measured in a 5-point Likert scale, as the agreement with the statement “I will use AV

ridehailing services with other passengers I don't know". Familiarity and use of shared ridehailing services were asked on the following scale: not familiar, familiar but not a user, use it rarely, use it monthly, and use it weekly; thus a 5-point ordinal indicator. The independent variables for this study, however, were adjusted to be estimated in three categories for willingness to ride in AV ridehailing services (*Disagree or Strongly disagree, Neutral, Agree or Strongly agree*), and two categories for the ridehailing usage (*User vs. Non-User*). Figure 1 shows the hypothesized model framework.

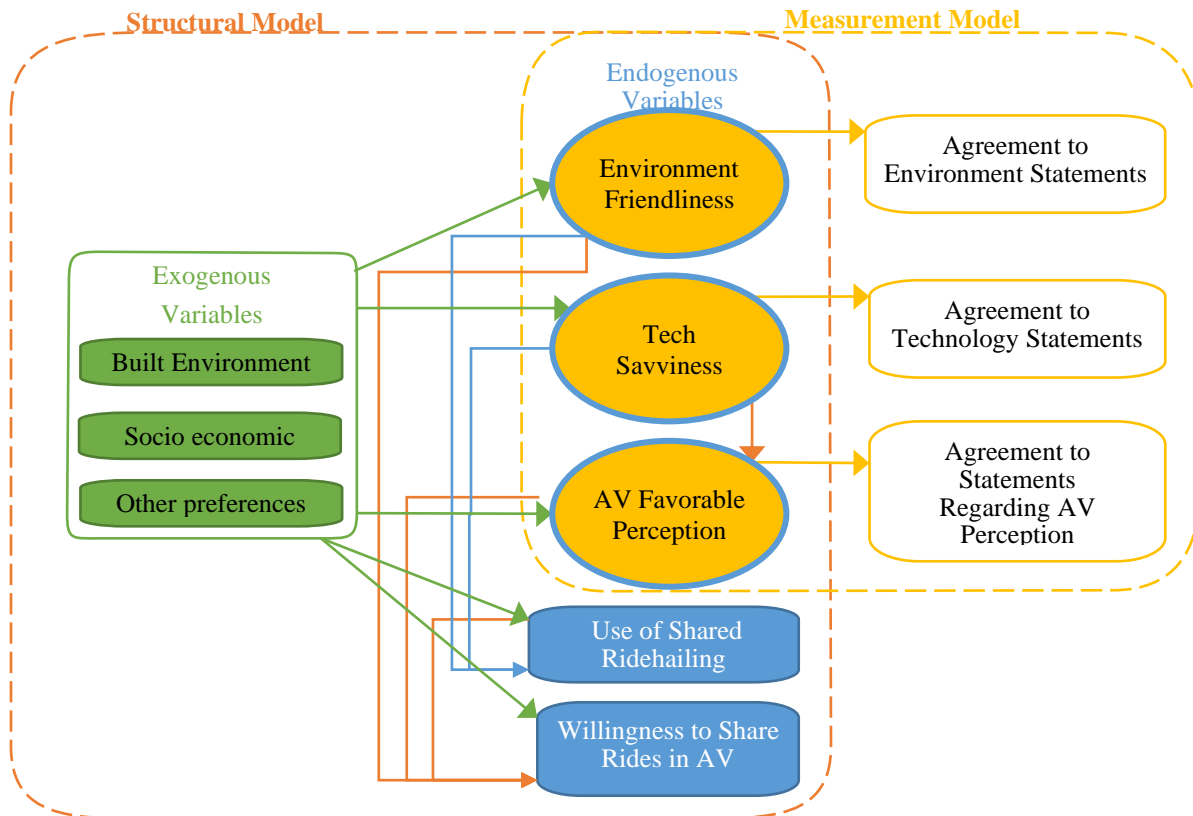

Figure 1 Proposed Model Framework for the Investigation of Women's Willingness to Share Rides in Autonomous Vehicles

Given the ordered categorical nature of both the indicators and measurements to the latent constructs, the chosen estimator for the proposed model was the Weighted Least Squares, adjusted for Means and Variance (WLSMV), with theta parameterization. The MPlus user guide defines the WLSMV estimator as “weighted least square parameter estimates using a diagonal weight matrix with standard errors and mean- and variance-adjusted chi-square test statistic that uses a full weight matrix” (Muthén & Muthén, 2017). This robust estimator uses Probit links to respect the categorical nature of the dependent variables. For a detailed description of the WLSMV estimator, please refer to Muthén et al. (1997). The theta parameterization ensures the residual variance is consistent with the scaling (Kline, 2016). The model was estimated using Version 8 of MPlus (Muthén & Muthén, 2017).

To understand the differences between men and women regarding their willingness to share rides on autonomous vehicles, a multi-group analysis was conducted. The male and female samples were separated into groups and modeled simultaneously. The hypothesis is that a

constrained model, where all the unstandardized parameters are forced to be equal, would not fit the sample well. It is also assumed that the constrained model would worsen the model fit of the unconstrained model, the latter being retained as the final solution. To test that difference, an unconstrained model is estimated, allowing the structural part of the model to be estimated freely across the samples (the measurement model is restricted to be equal), and then that solution is compared to a fully constricted model through a chi-square difference test. Since for the WLSMV estimator, chi-square difference tests cannot be computed directly, MPlus' function DIFFTEST was used to test the non-equality hypothesis. For a detailed explanation of the DIFFTEST computation, please refer to Asparouhov and Muthén (2006). According to the MPlus users' guide if the chi-square difference value is significant (p-value smaller than 0.05), then constraining the parameters to be equal across groups model significantly worsens the fit (Muthén & Muthén, 2017). In other words, to validate the hypothesis that men's and women's samples are different, and forcing all parameters to be equal for both genders would not describe well the phenomena under study, it is expected that the model difference chi-square test would have a p-value smaller than 0.05. Under this scenario, the unconstrained structural model is retained. Additionally, using multi-group analysis group difference, any specified parameter can be tested directly (Kline, 2016).

Additionally, as it is common practice in the transportation literature to consider gender as an exogenous variable in models, without further exploring how both samples fit the model separately, a one-group solution exploring the results for the model estimation on a sample that includes both men and women is also performed. The comparison between the multi-group and one-group analyses will allow for a better understanding of the benefits of multi-group analysis when exploring heterogeneity in travel behavior.

RESULTS

This results section is divided into three parts. First, a descriptive analysis of willingness to share rides in automated ridehailing services is shown for several market groups. All the descriptive analyses shown in the first and second sub-sections are weighted using the weights calculated as shown in Chapter 3, unless otherwise noticed. In the second sub-section, the results for the Decision Trees analyses are shown. Lastly, the results for the multi-group structural analysis are shown.

Descriptive Analysis

Table 3 shows how different market groups are willing to use autonomous vehicles as a pooled ridehailing service. Starting with gender, the main interest of this research, while 23% of men reported being willing to share rides in an AV ridehailing service, only 18% of women reported the same. A more detailed exploration of the gender differences on willingness to share across several market groups will be explored later in this subsection.

Regarding age, agreement with the statement "I will use AV ridehailing services with other passengers I don't know" decreases with age. Compared to respondents 18 to 30 years old at the time of the survey, those 71 years old and older reported being willing to use such a service 0.6 times less often. Increased education was associated with a higher interest in sharing AVs, as well as with a decrease in neutrality. The relationship between driver licensure and willingness to share revealed an interesting pattern; while it does not split the respondents into groups with different willingness to share per se, those without a driver's license are much more uncertain about how their agreement to the statement in question. This is particularly of interest as unlicensed adults are one of the groups who would benefit the most from automated vehicles, and they are also an

important patron group of ridehailing service providers.

Table 3 Willingness to Share Rides in Autonomous Vehicles for Different Socio-demographic and Attitudinal Groups (Weighted)

	Weighted sample	I will use AV ridehailing services with other passengers I don't know.		
		Disagree	Neutral	Agree
<i>Age (in 2019) grouped ($\chi^2=109.6, p=0.000$)</i>				
18-30 years	853	39.4%	34.9%	25.7%
31-40 years	609	49.8%	24.5%	25.8%
41-50 years	578	58.7%	23.2%	18.2%
51-60 years	527	59.2%	25.2%	15.6%
61-70 years	446	57.0%	26.2%	16.8%
71+ years	333	63.1%	21.9%	15.0%
<i>Gender ($\chi^2=27.3, p=0.000$)</i>				
Male	1629	47.9%	28.9%	23.1%
Female	1711	56.8%	25.1%	18.1%
<i>Highest level of education attained ($\chi^2=117.9, p=0.000$)</i>				
Some grade/high school	230	46.1%	38.7%	15.2%
Completed high school or GED	927	43.8%	36.5%	19.7%
Some college or technical school	1039	59.7%	23.4%	16.9%
Bachelor's degree(s) or some graduate school	748	52.7%	21.0%	26.3%
Completed graduate degree(s)	402	57.0%	19.2%	23.9%
<i>Place of birth ($\chi^2=9.4, p=0.009$)</i>				
United States or U.S. territory	2978	53.6%	26.8%	19.6%
Other country	318	45.0%	29.9%	25.2%
<i>Race ($\chi^2=69.8, p=0.000$)</i>				
White or Caucasian	2242	56.5%	24.3%	19.3%
Black or African American	427	44.3%	31.9%	23.9%
Native American	25	76.0%	8.0%	16.0%
Asian or Pacific Islander	237	42.6%	27.4%	30.0%
Other	66	74.2%	10.6%	15.2%
Multi race	138	47.1%	39.1%	13.8%
<i>Hispanic or Latino origin ($\chi^2=9.3, p=0.009$)</i>				
No	2683	53.3%	26.1%	20.5%
Yes	562	49.5%	32.4%	18.1%
<i>Driver licensure ($\chi^2=131.3, p=0.000$)</i>				
No	367	27.8%	50.4%	21.8%
Yes	2980	55.5%	24.2%	20.4%
<i>Employment status ($\chi^2=62.2, p=0.000$)</i>				
A worker (part-time or full-time)	1824	52.4%	25.3%	22.3%
Both a worker and a student	328	46.0%	29.6%	24.4%
A student (part-time or full-time)	301	39.5%	32.9%	27.6%
Neither a worker nor a student	893	59.2%	27.5%	13.2%
<i>Number of vehicles in the household ($\chi^2=123.2, p=0.000$)</i>				
0	187	27.3%	52.9%	19.8%
1	1173	47.0%	29.8%	23.2%
2	1351	56.2%	25.2%	18.7%
3	380	60.0%	18.2%	21.8%
4 or more	255	65.1%	18.4%	16.5%
<i>Relationship of number of cars with number of drivers in the household ($\chi^2=45.8, p=0.000$)</i>				
Car deficient (more drivers than cars in the household)	729	42.8%	36.2%	21.0%
Car sufficient (enough cars for all drivers)	2617	55.1%	24.5%	20.4%
<i>Tenure status ($\chi^2=71.9, p=0.000$)</i>				

	Weighted sample	I will use AV ridehailing services with other passengers I don't know.		
		Disagree	Neutral	Agree
Rent	1069	42.8%	31.0%	26.2%
Own	2022	57.2%	24.3%	18.5%
Provided by somebody else (e.g., relative, employer)	215	60.5%	28.4%	11.2%
<i>Annual household income before taxes ($\chi^2=136.2, p=0.000$)</i>				
Less than \$25,000	514	40.3%	37.4%	22.4%
\$25,000 to \$49,999	729	47.9%	29.9%	22.2%
\$50,000 to \$74,999	600	53.7%	25.2%	21.2%
\$75,000 to \$99,999	428	51.4%	34.3%	14.3%
\$100,000 to \$149,999	554	57.6%	20.9%	21.5%
\$150,000 to \$249,999	279	58.1%	12.5%	29.4%
\$250,000 or more	146	76.0%	14.4%	9.6%
<i>Children in the household ($\chi^2=11.1, p=0.0004$)</i>				
Not present	2703	52.5%	28.0%	19.6%
Present	646	52.3%	23.1%	24.6%
<i>Private ridehailing usage ($\chi^2=57.7, p=0.000$)</i>				
Not an user	1519	59.1%	25.2%	15.7%
User	1827	47.0%	28.5%	24.5%
<i>Shared ridehailing usage ($\chi^2=217.3, p=0.000$)</i>				
Not an user	2668	58.3%	25.5%	16.2%
User	679	29.5%	33.0%	37.6%
<i>Average miles driven in a week ($\chi^2=77.1, p=0.000$)</i>				
Zero	358	48.3%	34.1%	17.6%
1-25 miles	594	53.4%	29.6%	17.0%
26-50 miles	644	58.1%	22.5%	19.4%
51-75 miles	395	47.6%	35.9%	16.5%
76-100 miles	384	45.8%	25.8%	28.4%
101-200 miles	484	54.5%	20.9%	24.6%
201-300 miles	312	52.2%	28.8%	18.9%
More than 300 miles	175	56.0%	17.1%	26.9%
<i>Familiarity with Autonomous Vehicles ($\chi^2=174.9, p=0.000$)</i>				
I had never heard of AVs before taking this survey.	507	37.1%	46.7%	16.2%
I have heard of AVs, but don't know much about them.	1215	58.9%	22.6%	18.4%
I am somewhat familiar with AVs.	1163	53.7%	26.5%	19.8%
I am very familiar with AVs.	416	50.5%	17.3%	32.2%
I have actually taken a ride in an AV.	46	37.0%	23.9%	39.1%
<i>I like to be among the first people to have the latest technologies ($\chi^2=32.2, p=0.000$)</i>				
Disagree/Neutral	1531	57.0%	26.3%	16.7%
Agree	1814	48.5%	27.7%	23.8%
<i>I feel uncomfortable around people I do not know ($\chi^2=1.2, p=0.563$)</i>				
Disagree/Neutral	2257	52.0%	27.6%	20.4%
Agree	1087	53.4%	25.9%	20.8%
<i>I prefer to live close to transit, even if it means I'll have a smaller home and live in a more densely populated area. ($\chi^2=55.5, p=0.000$)</i>				
Disagree/Neutral	2359	56.3%	26.1%	17.6%
Agree	985	43.5%	29.3%	27.2%
<i>I am committed to using less polluting means of transportation as much as possible ($\chi^2=56.2, p=0.000$)</i>				
Disagree/Neutral	2107	56.6%	26.5%	16.9%
Agree	1237	45.4%	27.9%	26.8%
<i>I try to make good use of the time I spend traveling ($\chi^2=2.5, p=0.288$)</i>				
Disagree/Neutral	843	53.6%	27.8%	18.6%
Agree	2505	52.1%	26.8%	21.2%
<i>I like trying things that are new and different ($\chi^2=27.8, p=0.000$)</i>				

	Weighted sample	I will use AV ridehailing services with other passengers I don't know.		
		Disagree	Neutral	Agree
Disagree/Neutral	628	50.3%	34.6%	15.1%
Agree	2719	52.9%	25.3%	21.8%
<i>I definitely like the idea of owning my own car ($\chi^2=72.2, p=0.000$)</i>				
Disagree/Neutral	425	34.8%	31.8%	33.4%
Agree	2921	55.0%	26.3%	18.7%
<i>The time spent traveling to places provides a useful transition between activities ($\chi^2=43.9, p=0.000$)</i>				
Disagree/Neutral	1792	54.9%	28.9%	16.2%
Agree	1554	49.6%	24.9%	25.5%

Household characteristics were also evaluated as to their relationship with intention to use shared rides on automated ridehailing services. The relationship between income and willingness to use AV ridehailing services, however, was not clear. The income group with the lowest share of individuals willing to use shared AVs was the highest one; only about 10 percent of respondents who lived in households which incomes were higher than \$250,000 agreed to the statement about using AVs in a shared ridehailing service. Individuals living in households with children and car deficient households indicated a willingness to share that was only slightly higher when compared to their counterparts. The contrasts between the relationships between personal and household characteristics on willingness to share rides suggest that individual characteristics may play a larger role in such a decision.

Beyond the socioeconomic characteristics of respondents and their households, this study also considers the relationships between respondents' current travel behavior and general attitudes. Respondents who reported using shared ridehailing also reported being willing to use such a service if the vehicles are autonomous twice as often as those who were either not familiar with the service or had never used it before. Similar trends were observed regarding other attitudes and preferences. When compared to respondents who had never heard of AVs prior to the survey, those who had actually taken a ride in an autonomous vehicle reported being willing to use them as a shared-ride service more than twice as often. Those who agreed that they prefer living close to transit agreed to use AV shared services close to twice as often as those who either disagreed or were neutral to living close to transit.

Further multivariate analysis will further explore how these attributes contribute to shaping AV willingness to ride when they are considered at the same time. However, this descriptive analysis sheds some interesting light on what factors may be important and who are the individuals interested in using such a service. Importantly, other attributes in addition to gender must be considered in the analysis of willingness to share rides in an AV, such as other preferences and previous knowledge and usage of ridehailing shared services.

Gender Differences in Travel Behavior. As one of the goals of this dissertation chapter is to add a gendered perspective to the understanding of willingness to share rides in autonomous vehicles, it is important to explore how men and women differ in terms of their current travel behavior. Table 4 describes how travel behavior differed for the men and women who answered the T4 survey in 2019. While the differences in driver licensure and conditions limiting driving are not very prominent between the two groups, there are some noticeable distinctions in how men and women travel. Women, in general, drive slightly less and reported not having a vehicle to drive alone on non-commute trips twice as often as men. In this survey, male respondents reported using a bicycle on non-commute trips more often than women; while more than 5 percent of men said

they bike weekly, less than 2 percent of women reported the same. Regarding work-related trips, the most striking difference between men's and women's travel relates to long-distance trips for business purposes. While 17.5 percent of men travel for work more than once a year, only 8.8 percent of women travel for business purposes by plane that often. The frequency of long-distance trips by car is similar; close to half as many women reported traveling by car for business than men.

Table 4 Gender Differences in Travel Behavior (Weighted)

	Men	Women
<i>Average miles driven in a week ($\chi^2=53.4,p=0.000$)</i>	<i>N=1635</i>	<i>N=1715</i>
Zero	10.0%	11.4%
1-25 miles	14.8%	20.6%
26-50 miles	19.8%	18.7%
51-75 miles	11.6%	12.0%
76-100 miles	10.1%	12.5%
101-200 miles	18.0%	11.3%
201-300 miles	9.6%	9.1%
More than 300 miles	6.1%	4.4%
<i>Conditions that prevent or limit from Driving in general ($\chi^2=10.9,p=0.004$)</i>	<i>N=1636</i>	<i>N=1712</i>
No	89.9%	90.1%
To some extent	6.7%	4.8%
Yes	3.4%	5.1%
<i>Driver licensure ($\chi^2=12.9,p=0.000$)</i>	<i>N=1635</i>	<i>N=1715</i>
No	9.0%	12.9%
Yes	91.0%	87.1%
<i>Drive alone frequency on non-commute trips ($\chi^2=55.5,p=0.000$)</i>	<i>N=1625</i>	<i>N=1702</i>
Not available	8.4%	15.1%
Available but I never use it	3.6%	3.5%
I use it less than one day a month	4.1%	1.8%
I use it 1-3 days a month	8.3%	7.2%
I use it 1-2 days a week	15.9%	18.6%
I use it 3 or more days a week	59.8%	53.8%
<i>Ridehailing frequency on non-commute trips, private or shared ($\chi^2=31.8,p=0.000$)</i>	<i>N=1611</i>	<i>N=1692</i>
Not available	10.4%	15.4%
Available but I never use it	60.5%	58.9%
I use it less than one day a month	16.3%	12.6%
I use it 1-3 days a month	8.4%	8.1%
I use it 1-2 days a week	1.6%	2.9%
I use it 3 or more days a week	2.7%	2.1%
<i>Bicycle frequency on non-commute trips ($\chi^2=122.4,p=0.000$)</i>	<i>N=1607</i>	<i>N=1687</i>
Not available	31.1%	43.7%
Available but I never use it	46.7%	46.5%
I use it less than one day a month	10.6%	5.5%
I use it 1-3 days a month	6.1%	2.8%
I use it 1-2 days a week	1.9%	0.8%
I use it 3 or more days a week	3.6%	0.7%
<i>Walk frequency on non-commute trips ($\chi^2=51.5,p=0.000$)</i>	<i>N=1597</i>	<i>N=1692</i>
Not available	15.4%	22.3%
Available but I never use it	35.1%	35.5%
I use it less than one day a month	15.0%	12.9%
I use it 1-3 days a month	13.2%	10.8%
I use it 1-2 days a week	7.1%	9.5%
I use it 3 or more days a week	14.2%	9.0%
<i>Long distance trips by car for personal purposes since the beginning of the year</i>	<i>N=1590</i>	<i>N=1666</i>

	Men	Women
<i>($\chi^2=75.8, p=0.000$)</i>		
0	24.6%	33.9%
1	17.9%	20.2%
2	16.5%	12.8%
3	8.9%	10.7%
4	8.0%	7.0%
5	6.0%	5.3%
6 or more	18.2%	10.1%
<i>Long distance trips by plane for personal purposes since the beginning of the year</i>		
<i>($\chi^2=40.9, p=0.000$)</i>		
	N=1531	N=1639
0	49.6%	55.7%
1	18.4%	21.7%
2	16.7%	11.7%
3	4.5%	4.1%
4	4.0%	3.1%
5	2.2%	1.2%
6 or more	4.6%	2.5%
COMMUTE		
<i>Days per week respondent travels to work ($\chi^2=22.1, p=0.002$)</i>		
	N=1103	N=1053
0	8.8%	7.0%
1	4.9%	4.7%
2	5.2%	4.7%
3	5.6%	8.6%
4	11.5%	11.0%
5	50.2%	54.0%
6	8.7%	4.9%
7	5.1%	4.9%
<i>Commute length</i>		
Average commute time (minutes)	27.2	31.5
Average commute distance (miles)	21	13.7
<i>Means of transportation used most often for commute ($\chi^2=24.2, p=0.002$)</i>		
	N=1121	N=1047
Private vehicle, driving alone	69.3%	73.6%
Private vehicle, driving with passengers	6.2%	6.4%
Private vehicle, riding with others	4.7%	4.8%
Bus	10.0%	7.8%
Light rail	1.2%	1.4%
Uber/Lyft/other ridehailing services	0.8%	1.9%
Bicycle (including bikesharing)	2.5%	0.8%
Walk	5.0%	3.1%
Other mode	0.2%	0.2%
<i>Drive alone frequency on commute trips ($\chi^2=21.3, p=0.000$)</i>		
	N=1166	N=1057
Not available	11.2%	11.3%
Available but I never use it	7.0%	5.8%
I use it less than one day a month	3.3%	3.9%
I use it 1-3 days a month	6.1%	2.4%
I use it 1-2 days a week	4.2%	4.9%
I use it 3 or more days a week	68.1%	71.8%
<i>Ridehailing frequency on commute trips ($\chi^2=25.2, p=0.000$)</i>		
	N=1144	N=1054
Not available	12.5%	18.4%
Available but I never use it	65.3%	64.2%
I use it less than one day a month	10.8%	7.8%
I use it 1-3 days a month	5.5%	5.8%
I use it 1-2 days a week	1.4%	1.4%
I use it 3 or more days a week	4.5%	2.4%

	Men	Women
<i>Long distance trips by car for business purposes since the beginning of the year</i> ($\chi^2=25.8, p=0.000$)	N=1031	N=976
0	72.3%	81.6%
1	9.8%	6.5%
2	4.6%	3.6%
3	1.7%	1.1%
4	2.1%	1.0%
5	2.3%	1.3%
6 or more	7.2%	4.9%
<i>Long distance trips by plane for business purposes since the beginning of the year</i> ($\chi^2=57.1, p=0.000$)	N=1030	N=975
0	74.0%	84.1%
1	8.5%	7.1%
2	3.4%	3.2%
3	1.7%	1.2%
4	3.1%	2.3%
5	0.6%	0.5%
6 or more	8.6%	1.6%

Gender Differences in Ridehailing Usage. Another important aspect to be considered is how attitudes towards ridehailing differ among men and women. Figure 3 shows the share of men and women that agreed or strongly agreed with a set of attitudinal statements. Overall, the largest gender differences in perceptions towards ridehailing services regard sharing preferences. Even though both men and women equally disagree that the lower cost of shared ridehailing services is worth the additional time serving other passengers, women are much more uncomfortable with other individuals in their rides. While 35 percent of men are uncomfortable with traveling with an unfamiliar driver, 55 percent of women reported feeling the same way. For pooled rides, the difference is even larger; while 58 percent of women reported being uncomfortable traveling with unfamiliar passengers, only 44 percent of men reportedly feel the same.

In general, men and women use ridehailing with similar frequency (Smith, 2016). In this survey, about 55 percent of respondents were private ridehailing users and 20 percent were shared ridehailing users. An important note is that, at the time of the survey, shared ridehailing services were available in Austin and Atlanta, but not in Phoenix and Tampa; thus only part of the survey respondents had the option to use shared ridehailing locally. Men, however, reported spending more on ridehailing services, when compared to women's ridehailing average monthly expenditure (Table 5).

Table 5 Average Monthly Expenditure on Ridehailing Services, by Gender (Weighted)

	Male	Female	Total
Weighted sample:	838	845	1688
\$0	36.9%	49.8%	43.2%
\$1 - \$9	3.7%	7.8%	5.7%
\$10 - \$29	26.5%	18.7%	22.8%
\$30 - \$49	16.6%	11.1%	13.8%
\$50 - \$74	6.2%	5.1%	5.6%
\$75 - \$100	6.7%	5.6%	6.1%
More than \$100	3.5%	1.9%	2.7%

The T4 Survey, collected in 2019, asked respondents to detail their last trip using ridehailing services, whether it had been using private (e.g., Uber X or Lyft) or shared ridehailing

(e.g., UberPOOL or Lyft Line). Figure 2 shows the service type chosen by men and women on their last trip prior to the survey. Both when traveling alone and with friends, women chose shared ridehailing more frequently than men, a fact that is consistent with the observation that women have stronger preferences for carpooling services than men (Lippke & Noyce, 2020; Siddiqi, 2012).

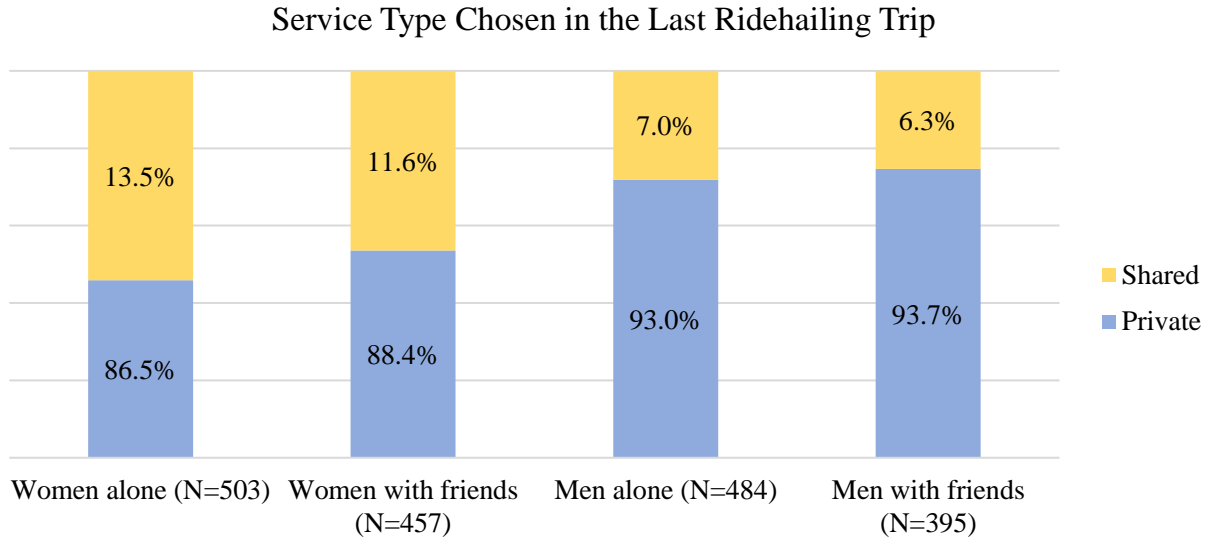

Figure 2 *Service Type Chosen in the Last Ridehailing Trip, by Gender and Companionship (Weighted)*

Table 6 shows how men and women differed in their reported last ridehailing trips, both on private and on shared rides. Looking first at the gender differences in the characteristics of their last trip using private ridehailing, women reported more often (12 percent versus 8 percent) that they would not have made the trip. This finding suggests that ridehailing more strongly encourages women to make trips that would otherwise not make. Women also reported more often to use private ridehailing services for accessing medical or dental appointments, whereas men more often reported using the service to go eating or drinking, and on social-recreational trips. Interestingly more women (34 percent) reported being unwilling to accept longer travel times for a reduced cost when compared to men (30 percent).

Differences in the reported last shared ridehailing trips also arise when comparing men's and women's responses to the T4 survey. Daytime trips during the week make up to twice the fraction of men's shared trips as it does on women's shared trips. Also, commuting was a trip purpose reported twice as often among men than among women. Additionally, while 27 percent of women who reported on their last shared ridehailing trip said they would have used a bus had ridehailing services not been available, only 19 percent of men would have done the same.

Table 6 Description of the Last Ridehailing Trip, by Gender and Service Type (Weighted)

	Private Ridehailing			Shared Ridehailing		
	Men	Women	Total	Men	Women	Total
Weighted sample	820	839	1659	70	121	191
<i>Companionship</i>						
Alone	54.9%	51.8%	53.3%	30.5%	20.7%	25.4%
With friends only	45.1%	48.2%	46.7%	37.3%	37.2%	39.6%
With matched passengers only				27.1%	35.5%	34.9%
With friends and matched passengers				5.1%	6.6%	0.0%
<i>Time of trip</i>						
Weekday daytime	41.5%	53.0%	47.3%	42.3%	47.9%	45.8%
Weeknight (excluding Friday night)	22.3%	14.2%	18.2%	19.7%	25.6%	23.4%
Weekend daytime	9.8%	7.5%	8.7%	16.9%	8.3%	11.5%
Weekend night time (including Friday night)	26.4%	25.2%	25.8%	21.1%	18.2%	19.3%
<i>Primary trip purpose</i>						
Main commute location	15.9%	14.1%	15.0%	20.3%	11.4%	14.6%
Shopping/errands	7.8%	4.4%	6.1%	21.7%	24.4%	23.4%
Eating/drinking	13.3%	9.3%	11.3%	8.7%	10.6%	9.9%
Social/recreational	27.1%	25.4%	26.2%	21.7%	16.3%	18.2%
To access airport	15.2%	12.4%	13.8%	13.0%	18.7%	16.7%
To access public transit	0.9%	0.5%	0.7%	0.0%	0.8%	0.5%
Medical/dental	3.4%	11.0%	7.3%	0.0%	2.4%	1.6%
Going/returning home from another location	11.5%	16.1%	13.8%	10.1%	11.4%	10.9%
Other	4.9%	6.7%	5.8%	4.3%	4.1%	4.2%
<i>Alternative mode used had ridehailing not been available</i>						
Drive private vehicle, alone	20.2%	17.0%	18.6%	17.4%	10.7%	13.1%
Drive private vehicle, with passengers	15.0%	14.6%	14.8%	13.0%	5.7%	8.4%
Ride private vehicle, with others	7.5%	14.2%	10.9%	7.2%	26.2%	19.4%
Ride the bus	8.5%	10.0%	9.3%	18.8%	27.0%	24.1%
Ride the light rail	3.5%	1.8%	2.6%	1.4%	0.8%	1.0%
Taxi	26.2%	18.1%	22.1%	11.6%	9.0%	9.9%
Bikesharing or e-scooter sharing service	0.5%	0.2%	0.4%	0.0%	1.6%	1.0%
Walk	3.0%	5.6%	4.3%	8.7%	4.9%	6.3%
Ride personal bicycle or scooter	2.4%	0.1%	1.3%	13.0%	0.0%	4.7%
Would not have made this trip	7.9%	12.0%	9.9%	2.9%	8.2%	6.3%
Other	5.3%	6.3%	5.8%	5.8%	5.7%	5.8%
<i>Willingness to add travel time had the shared trip been half of the price</i>						
I would not have used shared ridehailing for the trip	30.3%	34.2%	32.3%			
1-5 more minutes	16.3%	14.5%	15.4%			
6-10 more minutes	30.6%	24.8%	27.7%			
11-15 more minutes	11.9%	17.2%	14.6%			
16 or more minutes	10.9%	9.3%	10.1%			

Despite using shared services more often, women are more concerned about other passengers, and feel more uncomfortable around them (Lippke & Noyce, 2020; Bansal, Kockelman, & Singh, 2016). The results from the T4 survey show similar results. Figure 3 shows how the agreement to sentences about ridehailing services varied among men and women. While the gender differences are generally not significant, a clear pattern emerges when looking at being comfortable around others. Despite equally disagreeing that the lower cost of shared rides is worth the additional time, women feel uncomfortable around an unfamiliar driver and unfamiliar passengers significantly more often than men.

Share of Respondents Who Agree or Strongly Agree with Attitudinal Statements

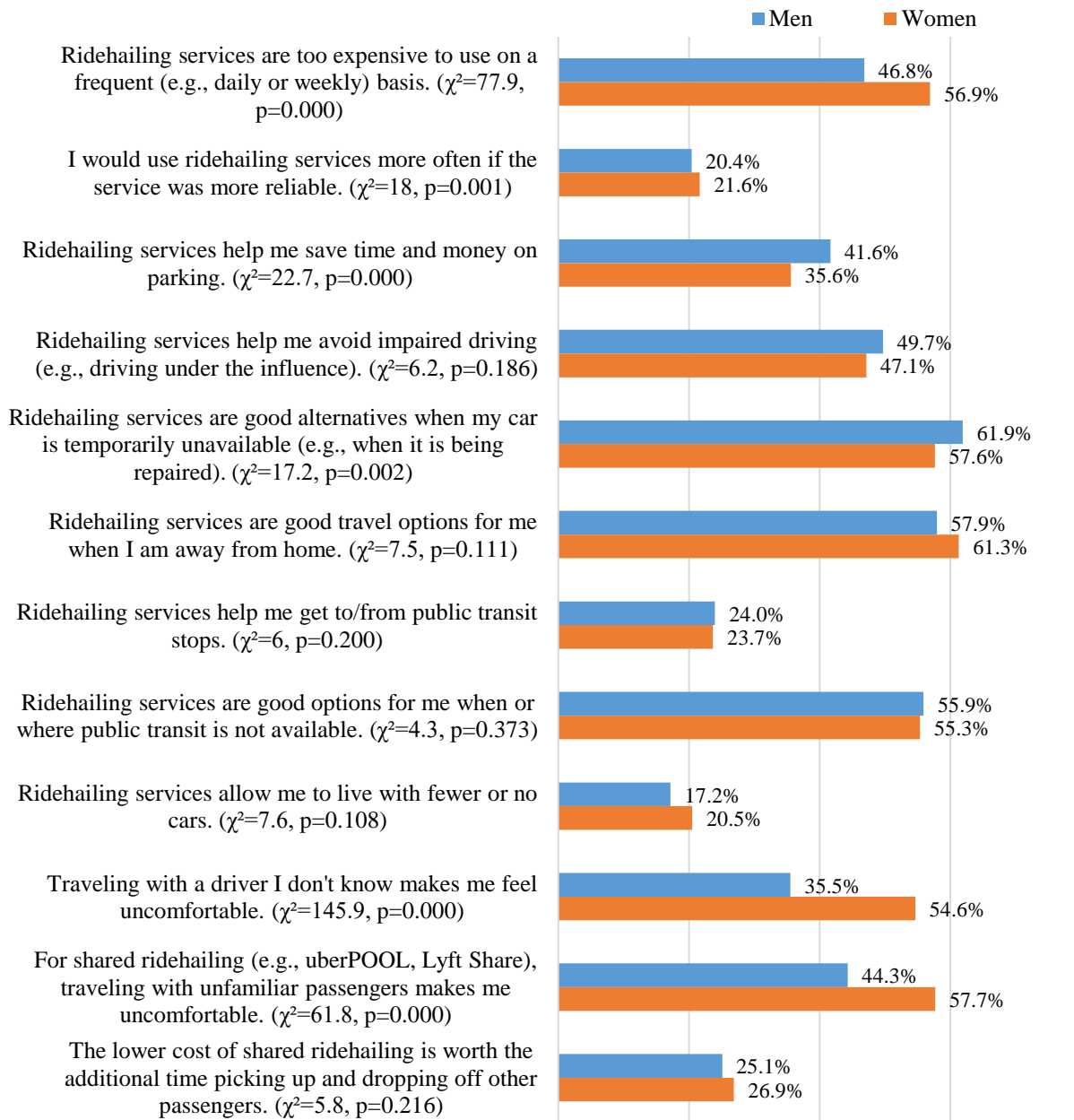

Note: χ^2 tests were performed using the distributions of agreement for all 5 points of the Likert scale. Therefore all tests have 4 degrees of freedom

Figure 3 Gender Differences on Attitudes Towards Ridehailing Services (Weighted)

Gender Differences in Attitudes. The differences in how men and women perceive the world around them do not end with ridehailing services. The T4 survey asked respondents to report their agreement with a series of attitudinal statements, and Figure 4 shows the gender differences in their responses. While men and women reported only small differences in their preferences towards doing only one thing at a time and having no alternatives to using a private vehicle, the agreement to other statements showed larger disparities. For example, men reported more often to enjoy being among the first to have the latest technologies and to be committed to using less

polluting means of transportation. Men also reported a much stronger preference for being a driver. On the other hand, women more often reported being too busy to do most of the things they enjoy doing and being uncomfortable around unfamiliar people. The differences in attitudes observed here, i.e. men being more tech-savvy and more concerned about the environment, will play an important role later in the analysis of willingness to share rides in autonomous vehicles.

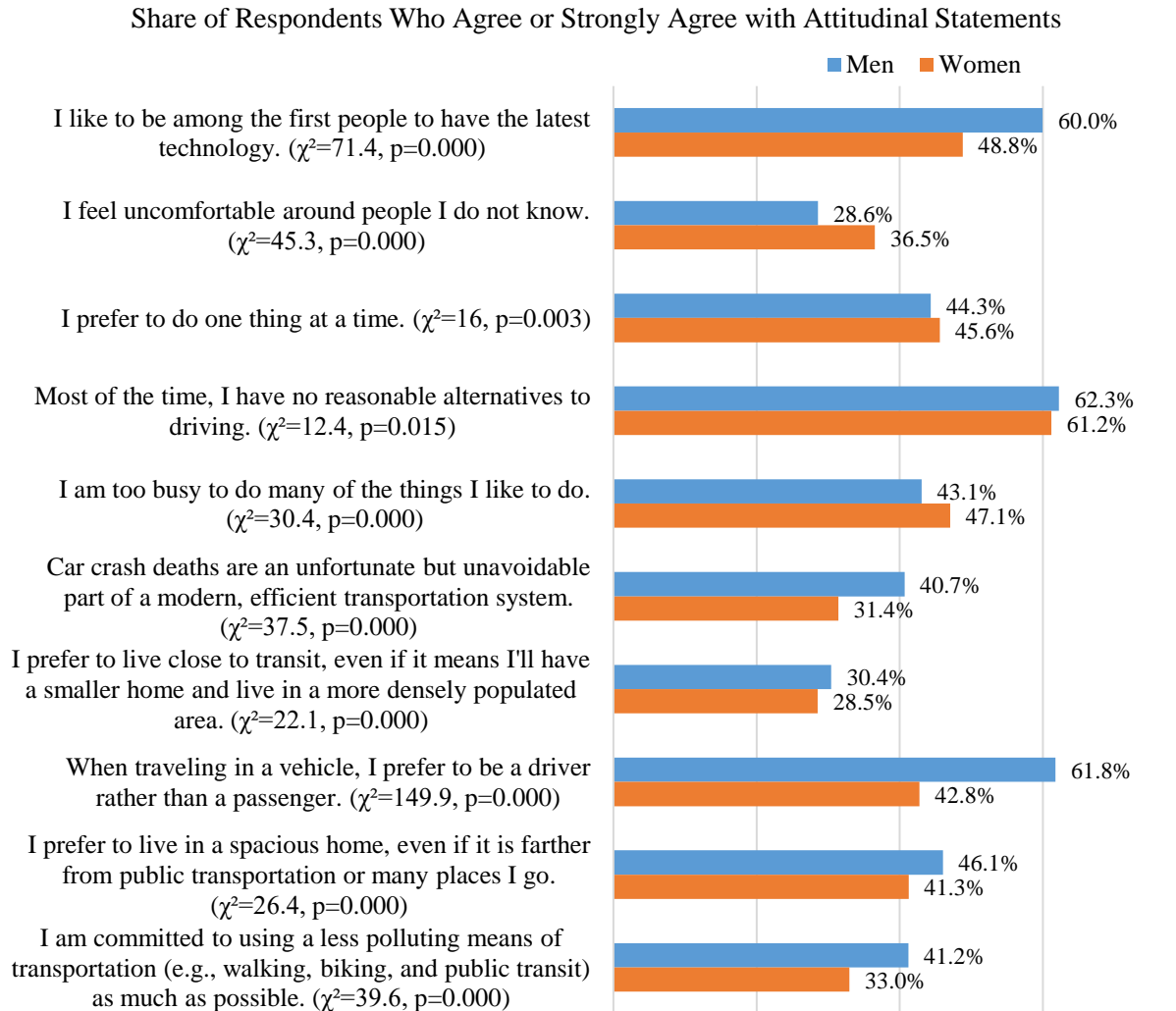

Note: χ^2 tests were performed using the distributions of agreement for all 5 points of the Likert scale.

Figure 4 Gender Differences in General Attitudes (Weighted)

Gender Differences in Perceptions towards Autonomous Vehicles. Not surprisingly, women also reported different views of autonomous vehicles as well as different intentions to use them in the future. Figure 5 shows the gender differences in the agreement to the statements about autonomous vehicles shown in the T4 survey in 2019. While men and women seem to be similarly concerned about potential data leaks regarding private data to be collected by AVs, all other statements showed a significant difference between male and female responses. Overall men seem to be more confident about the technology when compared to women. Women reported being more

concerned about equipment failure, reported less often that AVs would make them feel safer as a pedestrian or bicyclist, and are less interested in riding AVs, as 23 percent of them agreed with the statement “I will never ride in an AV”. Among men, only 15 percent believe they will never ride in an AV. Men also perceive the technology as potentially more useful. More men agreed that AVs will save them time and money for parking, and reported being willing to send AVs on errand trips by themselves.

Share of Respondents Who Agree or Strongly Agree with Attitudinal Statements

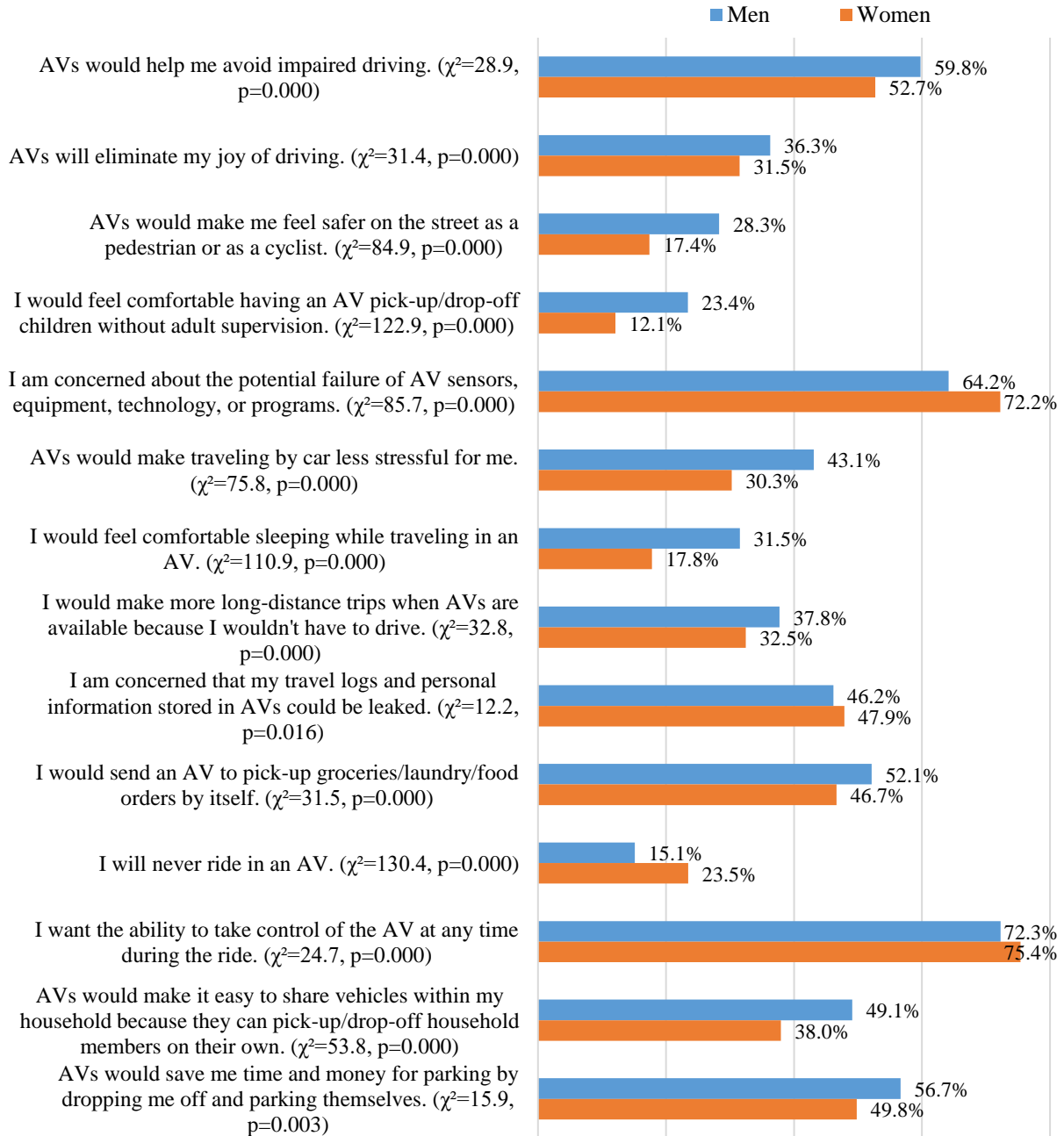

Note: χ^2 tests were performed using the distributions of agreement for all 5 points of the Likert scale. Therefore all tests have 4 degrees of freedom

Figure 5 Gender Differences on Attitude Towards Autonomous Vehicles (Weighted)

Error! Not a valid bookmark self-reference. expands the description of gender differences regarding autonomous vehicles. The table shows that women are less familiar with autonomous vehicles. While the largest share of men (40 percent) reported being somewhat familiar with AVs, the largest share of women (44 percent) reported having heard about them, without knowing much about how they work. Moreover, more men are willing to buy an autonomous vehicle, and among respondents who are willing to do so, men are willing to pay a larger premium to have their vehicles fully autonomous. Regarding potential additions to travel time due to AVs, men and women seem equally resistant to increase their commute time.

Table 7 *Gender Differences in Familiarity with Autonomous Vehicles, Willingness to Pay, Buy, and Increase Commute Time (Weighted)*

	Men	Women
<i>Familiarity with Autonomous Vehicles ($\chi^2=189.2, p=0.000$)</i>		
I had never heard of AVs before taking this survey.	12.4%	17.9%
I have heard of AVs, but don't know much about them.	27.8%	44.2%
I am somewhat familiar with AVs.	39.9%	29.9%
I am very familiar with AVs.	17.9%	7.1%
I have actually taken a ride in an AV.	2.0%	0.9%
<i>Additional time accepted on commute ($\chi^2=5.7, p=0.227$)</i>		
Up to 5 additional minutes (one way)	21.1%	21.0%
Between 5 and 15 additional minutes (one way)	29.1%	26.5%
Between 15 and 30 additional minutes (one way)	15.4%	13.7%
More than 30 additional minutes (one way)	6.0%	6.2%
I would not accept a longer commute even when I have access to an AV	28.4%	32.5%
<i>When respondent expects to buy an AV ($\chi^2=105.4, p=0.000$)</i>		
One of the first people to buy an AV	6.8%	3.1%
Eventually, but only after these vehicles are in common use	64.0%	51.3%
Never	29.2%	45.7%
<i>Willingness to pay for AV version of a \$25,000 vehicle ($\chi^2=20.7, p=0.000$)</i>		
Up to \$1,000 more	8.1%	8.0%
Between \$1,000 and \$3,000 more	16.3%	21.3%
Between \$3,000 and \$5,000 more	25.5%	27.4%
Between \$5,000 and \$8,000 more	18.4%	14.9%
Greater than \$8,000 more	11.1%	7.1%
Not willing to pay any additional amount	20.6%	21.3%

Regarding willingness to multitask during rides inside autonomous vehicles, men and women also answered the T4 survey differently. **Error! Not a valid bookmark self-reference.** shows that more men are willing to use the time in transit not used driving to work, sleep, play games,

and watch videos. Whereas, more women expect to use their phones while in transit. A larger number of women expect to be watching the road, even though they would not driving, suggesting a larger hesitancy among women in trusting the vehicle to perform all the necessary maneuvers for a safe ride.

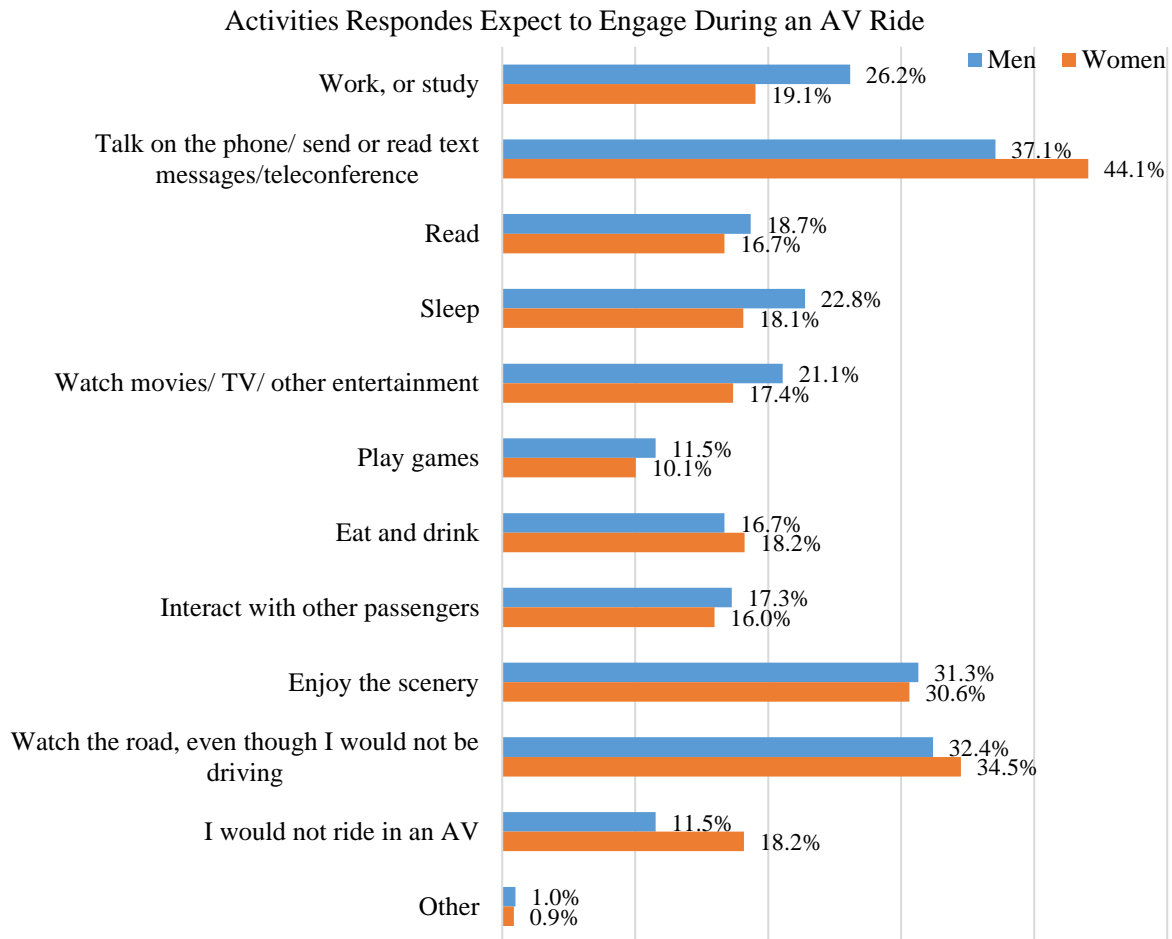

Figure 6 *Expected Activity Engagement During AV Rides, by Gender (Weighted)*

Much of the interest of this research is how men and women differ in their willingness to share rides in an autonomous ridehailing service. Table 8 shows the gender difference in willingness to use shared ridehailing services in AVs among several different market groups. Despite women being more interested in carpooling and in shared ridehailing services, overall men expressed a much larger interest in doing so when ridehailing services provide them using autonomous vehicles. Interestingly, only five subgroups of the sample had their women willing to share rides in AVs more than men. They were respondents between 61 and 70 years old, Latinas, respondents who were neither a worker nor a student at the time of the survey, respondents living in households with an annual income of \$250,000 or more, and respondents who were not users of private ridehailing services. While it is unclear why women in those groups reported a higher interest in sharing rides in AVs, further multivariate exploration of the issue will shed light on the underlying attitudes behind men and women’s decision to use those services.

Table 8 Gender Differences in Willingness to Share for Different Market Segments (Weighted)

Percent in each group willing to share rides in an AV ridehailing service	Men	Women
<i>Age (in 2019) grouped</i>		
18-30 years (N _{men} =374; N _{women} =412)	33.4%	18.2%
31-40 years (N _{men} =296; N _{women} =283)	28.0%	19.4%
41-50 years (N _{men} =230; N _{women} =339)	22.6%	15.6%
51-60 years (N _{men} =228; N _{women} =289)	18.4%	13.5%
61-70 years (N _{men} =246; N _{women} =191) ^a	13.4%	21.5%
71+ years (N _{men} =204; N _{women} =113)	16.2%	15.0%
<i>Highest level of education attained.</i>		
Some grade/high school (N _{men} =139; N _{women} =82)	19.4%	7.3%
Completed high school or GED (N _{men} =440; N _{women} =433)	18.6%	17.3%
Some college or technical school (N _{men} =455; N _{women} =544)	18.0%	17.1%
Bachelor's degree(s) or some graduate school (N _{men} =346; N _{women} =377)	35.0%	19.1%
Completed graduate degree(s) (N _{men} =199; N _{women} =192)	28.6%	18.2%
<i>Hispanic or Latino origin</i>		
No (N _{men} =1297; N _{women} =1307)	24.0%	16.8%
Yes (N _{men} =240; N _{women} =289) ^a	17.9%	20.1%
<i>Employment status</i>		
A worker (part-time or full-time) (N _{men} =913; N _{women} =838)	23.9%	19.6%
Both a worker and a student (N _{men} =149; N _{women} =157)	35.6%	14.6%
A student (part-time or full-time) (N _{men} =165; N _{women} =112)	33.3%	16.1%
Neither a worker nor a student (N _{men} =352; N _{women} =520) ^a	12.2%	14.4%
<i>Annual household income before taxes.</i>		
Less than \$25,000 (N _{men} =158; N _{women} =320)	32.3%	19.4%
\$25,000 to \$49,999 (N _{men} =311; N _{women} =414)	21.5%	18.4%
\$50,000 to \$99,999 (N _{men} =523; N _{women} =512)	22.0%	14.3%
\$100,000 to \$149,999 (N _{men} =342; N _{women} =241)	22.5%	18.7%
\$150,000 to \$249,999 (N _{men} =150; N _{women} =98)	32.7%	20.4%
\$250,000 or more (N _{men} =95; N _{women} =44) ^a	9.5%	11.4%
<i>Household drivers and household vehicles</i>		
Car deficient (N _{men} =349; N _{women} =376)	27.8%	15.2%
Car sufficient (N _{men} =1280; N _{women} =1336)	21.9%	19.0%
<i>Children in the household</i>		
Not present (N _{men} =1256; N _{women} =1341)	21.8%	17.7%
Present (N _{men} =323; N _{women} =286)	29.1%	14.7%
<i>Private ridehailing usage</i>		
Not an user (N _{men} =744; N _{women} =769) ^a	14.7%	16.9%
User (N _{men} =885; N _{women} =942)	30.3%	19.2%
<i>Shared ridehailing usage</i>		
Not an user (N _{men} =1299; N _{women} =1365)	17.5%	14.9%
User (N _{men} =328; N _{women} =345)	45.4%	30.7%
<i>Familiarity with Autonomous Vehicles</i>		
I had never heard of AVs before taking this survey. (N _{men} =191; N _{women} =279)	14.1%	13.6%
I have heard of AVs, but don't know much about them. (N _{men} =432; N _{women} =723)	19.0%	18.9%
I am somewhat familiar with AVs. (N _{men} =637; N _{women} =499)	22.9%	16.0%
I am very familiar with AVs. (N _{men} =287; N _{women} =113)	34.1%	20.4%
I have actually taken a ride in an AV. (N _{men} =31; N _{women} =14)	48.4%	21.4%
<i>I like to be among the first people to have the latest technologies</i>		
Disagree/Neutral (N _{men} =652; N _{women} =874)	18.9%	15.2%
Agree (N _{men} =977; N _{women} =835)	26.0%	21.2%
<i>I feel uncomfortable around people I do not know</i>		
Disagree/Neutral (N _{men} =1164; N _{women} =1085)	22.0%	18.9%
Agree (N _{men} =464; N _{women} =624)	26.1%	16.8%
<i>I am committed to using less polluting means of transportation as much as possible</i>		

Percent in each group willing to share rides in an AV ridehailing service	Men	Women
Disagree/Neutral (N _{men} =955; N _{women} =1146)	16.3%	17.5%
Agree (N _{men} =671; N _{women} =564)	32.8%	19.5%
<i>I definitely like the idea of owning my own car</i>		
Disagree/Neutral (N _{men} =217; N _{women} =203)	37.3%	29.6%
Agree (N _{men} =1412; N _{women} =1508)	20.9%	16.6%

Note. ^a Share of women in the group willing to share rides in AV ridehailing is larger than men.

Decision Tree Analysis

In addition to the descriptive analysis shown in the previous subsection of this chapter, a decision tree was grown to further identify the variables influencing respondents' willingness to share rides in autonomous ridehailing services. Figure 7 shows the resulting tree. Of all 12 end nodes of the tree, only two predict willingness to use shared ridehailing services, and they are both male nodes (Nodes 12 and 18). The end nodes for which the Decision Tree algorithm has predicted willingness to use autonomous pooled-ride services are transit-oriented men, previously a user of ridehailing services, that like the idea of owning their own cars, and male commuters that do not rate car ownership as important. This finding is consistent with the previous descriptive analysis showing women reporting interest in shared autonomous ridehailing services at lower rates than men.

The first level of the tree shows that the most important variable in dividing the sample into two homogenous groups regarding willingness to share rides in autonomous ridehailing services is the preference towards owning a private vehicle. Those who do not find car ownership as important were willing to share rides more often than their counterparts. On the left branch, Node 1 is then divided into groups who believed public transit is a reliable solution for their transportation needs and those who disagreed with that statement. Transit-oriented respondents reported being willing to share their AV ridehailing rides more often. Node 4 is also consistent with the previously shown descriptive analysis, as it is divided by private ridehailing usage and those who used the service at the time of the survey were also more frequently willing to use autonomous shared-ride services. The division of Node 8 by education attainment also shows an interesting pattern: those with a bachelor's degree or higher levels of education are more likely to accept shared rides than their less-educated counterparts.

To understand how much each variable contributes to explaining willingness to share rides in autonomous ridehailing services, variable importance is shown in Figure 8. The most important attribute in separating the sample into homogenous groups regarding their decision to share rides or not is a preference towards owning their own vehicle. The second most important attribute is population density at their home block group. Living in denser neighborhoods would support the sharing of rides, and encourage more efficient ride-sharing, possibly with lower increases in travel time. The third most important variable is gender; thus the most important sociodemographic attribute in explaining willingness to share rides in autonomous ridehailing services. This finding supports the deeper exploration of the underlying motives defining women's decision to not use autonomous ridehailing pooled services, as they currently do in regular vehicles.

Figure 7 Decision Tree Result for Exploring Willingness to Share Rides in an Autonomous Vehicle Ridehailing Service

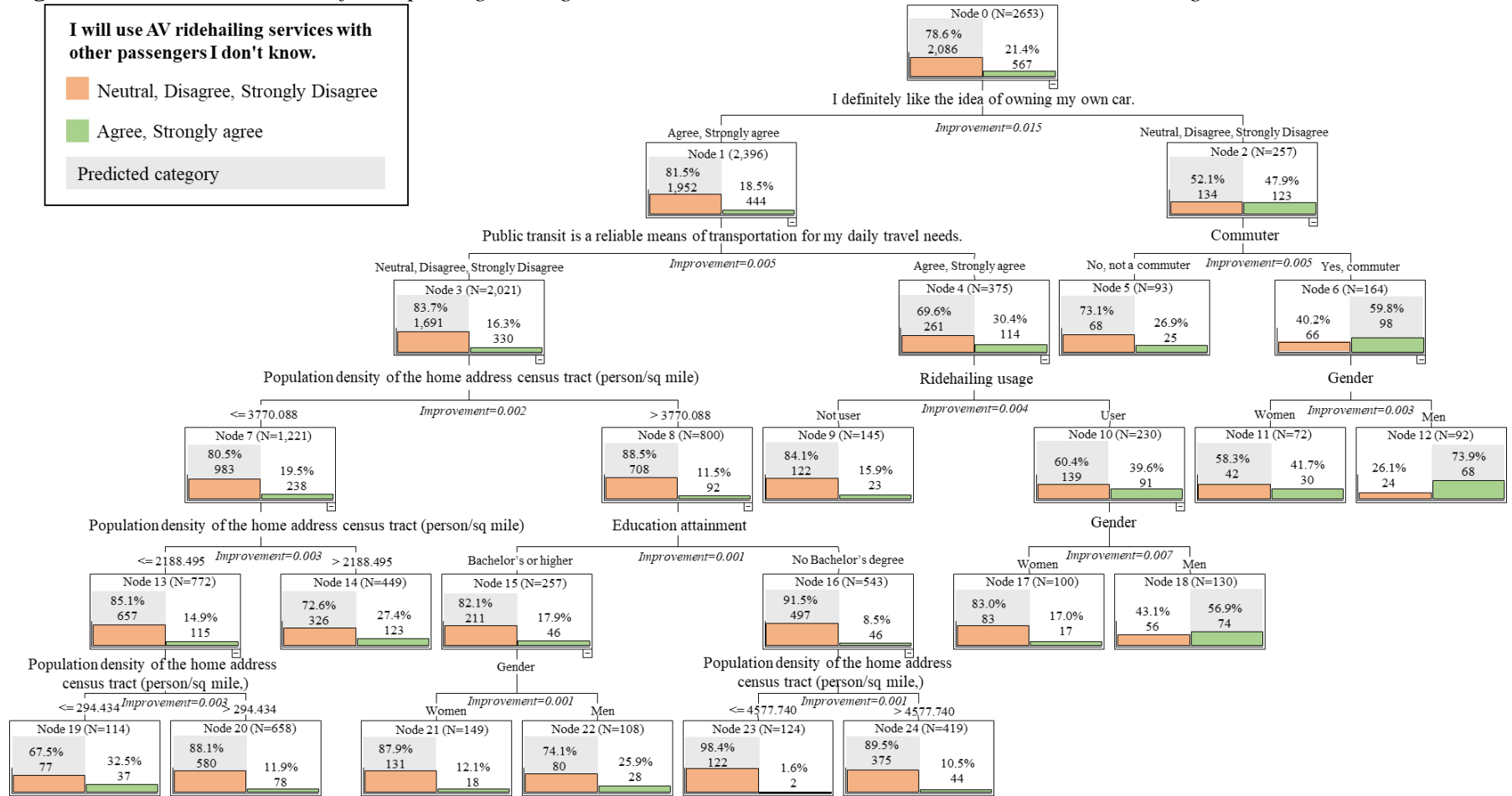
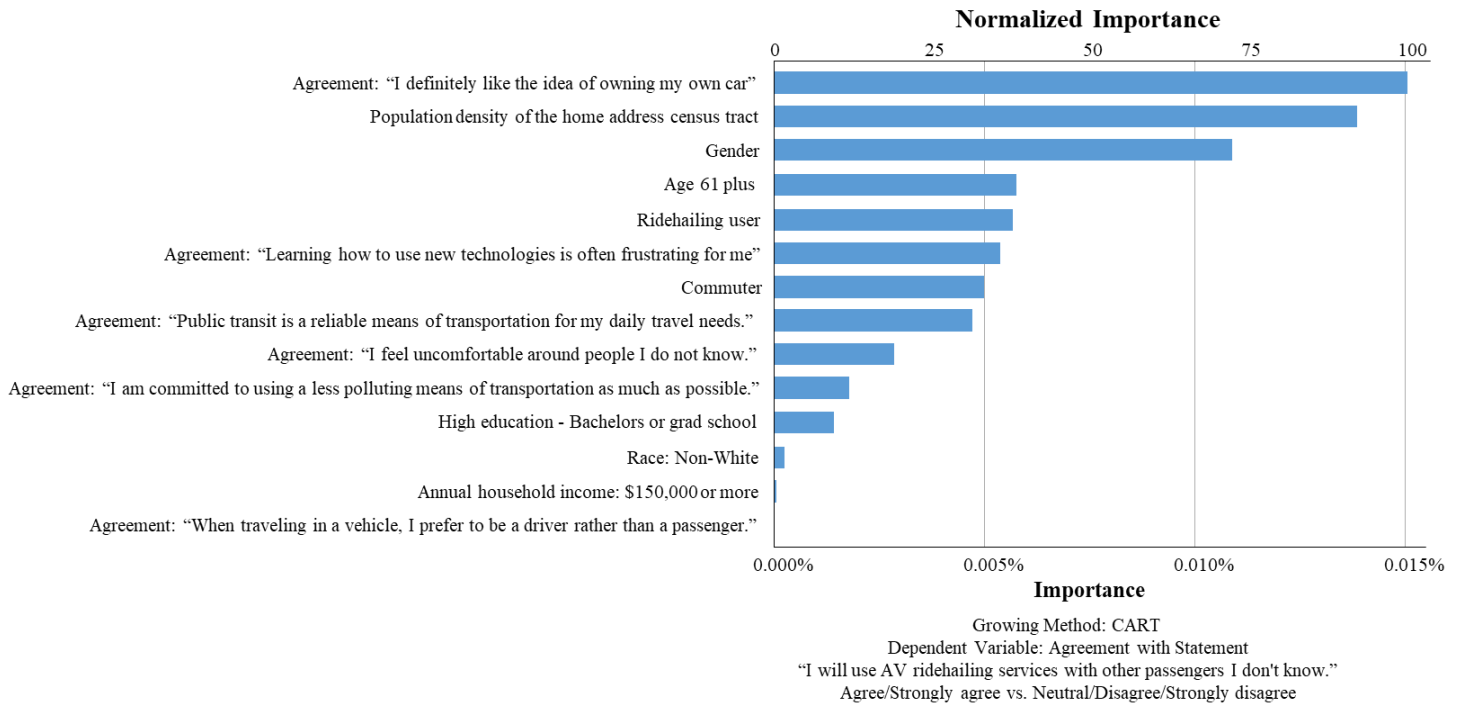

Figure 8 Variable Importance for Growing Decision Tree Exploring Willingness to Share Rides in AV Ridehailing Trips



Multi-Group Structural Equation Model

This subsection explores the results of a multi-group structural equation model framework that explores men’s and women’s willingness to share rides in autonomous ridehailing services. Table 9 shows the full unstandardized and standardized results both for the multi-group approach and for the one group approach. Further in the text, the results will be detailed with the assistance of illustrations.

Table 9 Full Model Results For Two-Group and One Group Solution Investigating Willingness to Share Rides in Autonomous Vehicles

Estimate (t-stat)	Unstandardized			Standardized		
	Men	Women	One Group	Men	Women	One Group
<i>Environment Friendliness MEASURED BY</i>						
Committed to environmentally-friendly lifestyle	1 (999)	1 (999)	1 (999)	0.674 (28.33)	0.595 (26.67)	0.633 (32.644)
Government should raise the gas tax	1.173 (14.956)	1.173 (14.956)	1.174 (15.677)	0.529 (22.138)	0.496 (21.1)	0.517 (25.17)
Committed to less polluting means of transportation	1.333 (17.902)	1.333 (17.902)	1.328 (18.395)	0.745 (31.165)	0.624 (27.455)	0.683 (34.398)
<i>Technology Savviness MEASURED BY</i>						
Like to be the first to have latest technology	1 (999)	1 (999)	1 (999)	0.585 (23.593)	0.527 (23.079)	0.571 (27.967)
Having internet connectivity everywhere is important	0.663 (12.732)	0.663 (12.732)	0.637 (12.868)	0.379 (14.97)	0.361 (15.225)	0.367 (16.572)
Learning how to use new technologies is frustrating	-0.783 (-13.724)	-0.783 (-13.724)	-0.769 (-13.905)	-0.449 (-17.499)	-0.404 (-17.635)	-0.431 (-19.758)
I like trying things that are new and different	0.662 (14.872)	0.662 (14.872)	0.614 (14.941)	0.558 (22.4)	0.493 (20.621)	0.5 (24.152)
<i>AV Favorable Perception MEASURED BY</i>						
AVs will reduce car stress	1 (999)	1 (999)	1 (999)	0.859 (48.428)	0.752 (45.944)	0.791 (66.846)
AVs will help reduce impaired driving	0.609 (20.491)	0.609 (20.491)	0.607 (21.294)	0.486 (24.101)	0.455 (24.63)	0.468 (29.297)
Concerned with equipment failure	-0.338 (-15.579)	-0.338 (-15.579)	-0.366 (-16.642)	-0.295 (-16.518)	-0.295 (-17.686)	-0.319 (-19.825)
Feel comfortable sleeping in an AV	0.881 (25.745)	0.881 (25.745)	0.919 (26.67)	0.704 (35.008)	0.685 (39.041)	0.719 (50.654)
AVs make feel safer as a pedestrian or bicyclist	0.863 (28.662)	0.863 (28.662)	0.873 (30.018)	0.755 (41.479)	0.71 (44.359)	0.735 (61.72)
<i>Technology Savviness REGRESSED ON</i>						
Age between 18 and 30 y.o.	0.277 (3.474)	0.275 (4.697)	0.281 (5.864)	0.164 (3.578)	0.216 (4.894)	0.191 (6.103)
Age between 31 and 40 y.o.	0.181 (2.26)	0.128 (2.08)	0.146 (2.913)	0.083 (2.279)	0.072 (2.09)	0.072 (2.931)
Age 61 and over	-0.322 (-4.973)	-0.223 (-4.002)	-0.278 (-6.433)	-0.24 (-5.298)	-0.159 (-4.103)	-0.2 (-6.773)
Female	-	-	-0.148 (-4.823)	-	-	-0.114 (-4.93)
I try to make good use of the time I spend traveling	0.531 (9.306)	0.471 (9.925)	0.503 (12.755)	0.336 (10.425)	0.322 (10.934)	0.319 (14.917)
<i>Environment Friendliness REGRESSED ON</i>						
Female	-	-	0.012 (0.48)	-	-	0.01 (0.48)
Hispanic	0.152 (2.164)	0.012 (0.296)	0.06 (1.665)	0.073 (2.175)	0.009 (0.297)	0.035 (1.669)
High Education - Bachelor's or Graduate degree	0.219 (4.879)	0.128 (3.968)	0.153 (5.814)	0.168 (5.056)	0.121 (4.024)	0.131 (5.971)
Age between 31 and 40 y.o.	0.133 (1.836)	-0.142 (-2.871)	-0.037 (-0.902)	0.064 (1.85)	-0.091 (-2.898)	-0.021 (-0.902)
Like the idea to own a car	-0.273 (-4.253)	-0.352 (-7.016)	-0.341 (-8.482)	-0.149 (-4.364)	-0.219 (-7.457)	-0.197 (-9.071)
I try to make good use of the time I spend traveling	0.316 (6.611)	0.301 (7.893)	0.307 (10.116)	0.212 (7.006)	0.234 (8.378)	0.22 (10.925)
<i>AV Favorable Perception REGRESSED ON</i>						
Technology Savviness	0.648 (9.592)	0.44 (7.241)	0.523 (11.484)	0.411 (12.216)	0.281 (8.235)	0.342 (14.49)
<i>AV Favorable Perception REGRESSED ON</i>						
Female	-	-	-0.395 (-9.744)	-	-	-0.199 (-10.239)
Age between 31 and 40 y.o.	0.314 (2.99)	0.13 (1.629)	0.203 (3.214)	0.091 (3.01)	0.046 (1.632)	0.066 (3.226)
High Education - Bachelor's or Graduate degree	0.2 (2.914)	0.06 (1.135)	0.113 (2.758)	0.092 (2.935)	0.032 (1.136)	0.056 (2.77)

Estimate (t-stat)	Unstandardized			Standardized		
	Men	Women	One Group	Men	Women	One Group
Atlanta, GA	-0.085 (-1.127)	-0.173 (-2.702)	-0.144 (-3.006)	-0.037 (-1.129)	-0.086 (-2.728)	-0.067 (-3.02)
Tampa, FL	-0.33 (-2.533)	-0.026 (-0.268)	-0.164 (-2.137)	-0.083 (-2.552)	-0.007 (-0.268)	-0.044 (-2.142)
Prefer to be a driver	-0.297 (-4.492)	-0.257 (-5.083)	-0.258 (-6.542)	-0.137 (-4.609)	-0.138 (-5.212)	-0.131 (-6.725)
<i>Shared Ridehailing Usage MEASURED ON</i>						
Environment Friendliness	0.384 (4.5)	0.204 (2.394)	0.296 (5.007)	0.196 (4.845)	0.09 (2.446)	0.142 (5.259)
Tech Savviness	0.36 (3.928)	0.377 (4.133)	0.36 (5.732)	0.195 (4.23)	0.189 (4.45)	0.194 (6.252)
<i>Shared Ridehailing Usage MEASURED ON</i>						
Female			0.038 (0.664)			0.016 (0.664)
Age between 18 and 30 y.o.	0.713 (4.732)	0.64 (5.889)	0.643 (7.485)	0.227 (4.814)	0.252 (6.009)	0.236 (7.631)
Age between 31 and 40 y.o.	0.323 (2.105)	0.273 (2.348)	0.305 (3.364)	0.08 (2.107)	0.077 (2.357)	0.081 (3.374)
Age 61 and over	-0.251 (-1.862)	0.104 (0.867)	-0.049 (-0.559)	-0.101 (-1.869)	0.037 (0.868)	-0.019 (-0.559)
Commuter	0.101 (0.836)	0.308 (3.186)	0.239 (3.229)	0.04 (0.839)	0.12 (3.22)	0.094 (3.256)
No vehicles in the household	0.2 (0.785)	0.321 (2.048)	0.354 (2.726)	0.028 (0.786)	0.056 (2.057)	0.058 (2.739)
Atlanta, GA	0.283 (2.285)	0.467 (4.392)	0.414 (5.226)	0.106 (2.305)	0.181 (4.473)	0.158 (5.311)
Tampa, FL	0.168 (0.88)	-0.365 (-2.053)	-0.09 (-0.714)	0.036 (0.881)	-0.081 (-2.062)	-0.02 (-0.714)
Austin, TX	0.508 (3.471)	0.493 (4.241)	0.514 (5.77)	0.183 (3.553)	0.202 (4.331)	0.201 (5.907)
Car sufficient household	-0.15 (-1.163)	-0.198 (-2.252)	-0.195 (-2.735)	-0.045 (-1.165)	-0.064 (-2.265)	-0.062 (-2.747)
<i>Willingness to Share Rides in an AV Ridehailing Service REGRESSED ON</i>						
AV Favorable Perception	0.407 (9.964)	0.643 (13.082)	0.545 (16.615)	0.344 (11.498)	0.478 (18.439)	0.432 (21.928)
Environment Friendliness	0.221 (3.141)	0.023 (0.287)	0.123 (2.37)	0.112 (3.192)	0.01 (0.286)	0.057 (2.377)
<i>Willingness to Share Rides in an AV Ridehailing Service REGRESSED ON</i>						
Shared ridehailing usage	0.279 (6.01)	0.239 (6.012)	0.25 (8.402)	0.277 (6.7)	0.226 (6.448)	0.241 (9.087)
Female			-0.173 (-3.523)			-0.069 (-3.525)
Condition limiting walking	-0.321 (-1.937)	-0.146 (-0.977)	-0.208 (-1.925)	-0.064 (-1.944)	-0.028 (-0.978)	-0.041 (-1.928)
Commuter	0.169 (1.772)	0.086 (0.987)	0.126 (2.011)	0.067 (1.785)	0.031 (0.988)	0.048 (2.016)
Like the idea to own a car	-0.351 (-3.098)	-0.423 (-3.902)	-0.379 (-4.916)	-0.097 (-3.124)	-0.109 (-3.952)	-0.101 (-4.961)
Condition limiting driving	0.302 (2.386)	-0.124 (-1.35)	0.037 (0.514)	0.075 (2.398)	-0.038 (-1.353)	0.011 (0.514)
Prefer to be a driver	0.013 (0.167)	-0.146 (-2.212)	-0.084 (-1.714)	0.005 (0.167)	-0.058 (-2.218)	-0.034 (-1.717)
Income less than \$25,000	0.181 (1.785)	0.16 (2.017)	0.145 (2.38)	0.059 (1.791)	0.058 (2.027)	0.051 (2.387)
<i>AV Favorable Perception CORRELATED WITH</i>						
Environment Friendliness	0.125 (6.023)	0.087 (5.652)	0.108 (8.35)	0.23 (6.446)	0.205 (5.963)	0.225 (9.025)
<i>Intercepts</i>						
Committed to environmentally-friendly lifestyle	3.616 (31.091)	3.616 (31.091)	3.588 (46.052)	3.898 (26.324)	4.149 (28.324)	3.968 (41.648)
Government should raise the gas tax	2.741 (17.731)	2.741 (17.731)	2.874 (24.661)	1.977 (15.17)	2.236 (16.202)	2.21 (22.026)
Committed to less polluting means of transportation	3.445 (23.471)	3.445 (23.471)	3.524 (34.807)	3.079 (20.396)	3.112 (21.267)	3.166 (31.641)
Like to be the first to have latest technology	3.073 (24.722)	3.073 (24.722)	3.207 (33.431)	2.717 (21.826)	2.744 (21.859)	2.843 (30.172)
Having internet connectivity everywhere is important	3.435 (29.257)	3.435 (29.257)	3.337 (33.455)	2.974 (23.999)	3.17 (25.987)	2.985 (30.685)

Estimate (t-stat)	Unstandardized			Standardized		
	Men	Women	One Group	Men	Women	One Group
Learning how to use new technologies is frustrating	2.64 (21.706)	2.64 (21.706)	2.493 (24.149)	2.291 (18.312)	2.307 (19.584)	2.167 (21.931)
Like things that are new and different	3.483 (40.592)	3.483 (40.592)	3.458 (51.707)	4.442 (34.584)	4.398 (34.833)	4.375 (46.446)
AVs will reduce car stress	3.146 (18.187)	3.146 (18.187)	3.229 (28.633)	2.589 (16.517)	2.555 (16.856)	2.595 (26.38)
AVs will help reduce impaired driving	3.389 (23.046)	3.389 (23.046)	3.403 (28.005)	2.595 (19.504)	2.735 (20.975)	2.666 (25.832)
Concerned with equipment failure	3.183 (27.346)	3.183 (27.346)	3.016 (29.04)	2.67 (22.08)	3.003 (24.394)	2.675 (26.669)
Feel comfortable sleeping in an AV	2.652 (15.597)	2.652 (15.597)	2.847 (24.19)	2.031 (14.202)	2.225 (14.607)	2.263 (22.27)
AVs make feel safer as a pedestrian or bicyclist	3.004 (18.639)	3.004 (18.639)	3.083 (28.651)	2.52 (16.792)	2.671 (17.395)	2.635 (26.242)
Environment Friendliness	0 (999)	0.08 (0.617)		0 (999)	0.154 (0.618)	
Technology Savviness	0 (999)	-0.026 (-0.191)		0 (999)	-0.045 (-0.191)	
AV Favorable Perception	0 (999)	-0.28 (-1.34)		0 (999)	-0.303 (-1.34)	
	<i>Thresholds</i>					
SHARED RH\$1	1.269 (4.96)	1.577 (8.011)	1.447 (9.682)	1.038 (5.123)	1.336 (8.393)	1.21 (10.114)
AVRH\$1	0.045 (0.221)	-0.232 (-1.132)	-0.26 (-1.945)	0.037 (0.222)	-0.186 (-1.132)	-0.21 (-1.945)
AVRH\$2	0.841 (4.042)	0.507 (2.455)	0.495 (3.655)	0.682 (4.07)	0.407 (2.453)	0.399 (3.653)
	<i>Residual Variances</i>					
Committed to environmentally-friendly lifestyle	0.469 (16.189)	0.491 (21.274)	0.49 (24.8)	0.545 (16.975)	0.646 (24.348)	0.6 (24.434)
Government should raise the gas tax	1.383 (15.093)	1.132 (18.762)	1.239 (26.86)	0.72 (28.419)	0.754 (32.287)	0.733 (34.578)
Committed to less polluting means of transportation	0.556 (11.865)	0.748 (18.116)	0.661 (20.326)	0.445 (12.469)	0.61 (21.495)	0.534 (19.695)
Like to be the first to have latest technology	0.842 (18.209)	0.905 (20.824)	0.857 (27.164)	0.658 (22.724)	0.722 (29.976)	0.674 (28.896)
Having internet connectivity everywhere is important	1.142 (19.917)	1.021 (22.954)	1.082 (31.751)	0.856 (44.56)	0.87 (50.796)	0.865 (53.289)
Learning how to use new technologies is frustrating	1.06 (17.374)	1.097 (20.835)	1.078 (28.455)	0.798 (34.608)	0.837 (45.239)	0.815 (43.4)
Like things that are new and different	0.423 (21.375)	0.474 (24.795)	0.468 (32.594)	0.689 (24.766)	0.757 (32.034)	0.75 (36.213)
AVs will reduce car stress	0.388 (8.842)	0.659 (16.686)	0.58 (25.501)	0.263 (8.639)	0.435 (17.672)	0.374 (19.998)
AVs will help reduce impaired driving	1.303 (17.126)	1.219 (22.256)	1.272 (31.826)	0.764 (38.94)	0.793 (47.258)	0.781 (52.274)
Concerned with equipment failure	1.298 (19.154)	1.026 (26.983)	1.142 (34.489)	0.913 (86.405)	0.913 (92.802)	0.898 (87.452)
Feel comfortable sleeping in an AV	0.859 (13.597)	0.755 (18.498)	0.766 (27.657)	0.504 (17.801)	0.531 (22.136)	0.484 (23.716)
AVs make feel safer as a pedestrian or bicyclist	0.611 (14.158)	0.627 (19.811)	0.63 (30.592)	0.43 (15.652)	0.496 (21.806)	0.46 (26.326)
Environment Friendliness	0.349 (11.158)	0.238 (11.36)	0.295 (13.598)	0.891 (43.273)	0.885 (47.227)	0.9 (70.225)
Technology Savviness	0.333 (8.806)	0.282 (9.246)	0.331 (10.828)	0.762 (23.148)	0.809 (28.652)	0.798 (38.941)
AV Favorable Perception	0.844 (12.599)	0.761 (13.124)	0.786 (16.248)	0.776 (26.587)	0.888 (40.84)	0.812 (45.061)

Error! Reference source not found. illustrates the unstandardized solution for the measurement part of the two-group analysis. As the estimates and standard errors are virtually the same for the two-group and the one-group analysis, and the standardized solutions are shown in the table, only the unstandardized two-group solutions are shown. It is important to highlight that, for the two-group analysis, the measurement model is constrained to be the same for both male and female samples. This assumption ensures that, when analyzing the structural portion of the model, the latent constructs were measured in the same way and have similar meanings for both men and women.

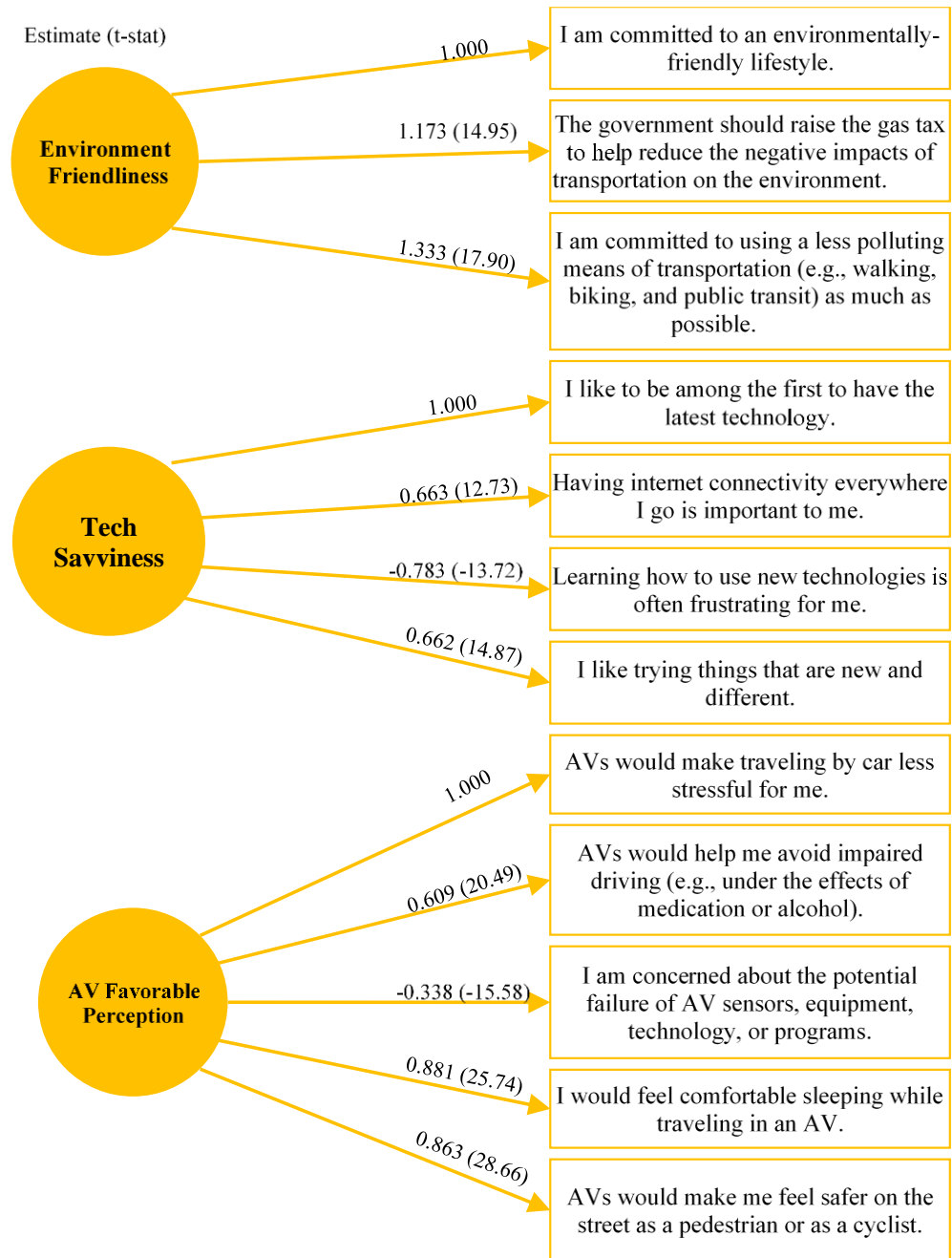

Figure 9 Measurement Model Results of the Willingness to Share Rides in Autonomous Vehicles

(Unstandardized Results)

All latent constructs were measured in the exact same way as in the previous chapter. As for the purposes of this analysis, the AV Adoption latent construct is not estimated, and the solutions are slightly different. However, the relationships between the measurements and the constructs are the same, and the constructs can still be interpreted in the same way. For example, agreement with the statements “Learning how to use new technologies is often frustrating to me” and “I am concerned about the potential failure of AV sensors, equipment, technology, and programs” are both negative on the constructs they define, as they represent opposite attitudes as the constructs are defined upon.

To aid in explaining the estimates between the exogenous variables and the endogenous variables shown in Table 9,

shows the effect directions without the estimates. Blue arrows indicate relationships significant on the male model only, red arrows indicate relationships significant on the female model only, whereas black arrows represent relationships significant on both models of the two-group solution. Dotted arrows indicate negative estimates. As it was considered in the previous chapter, AV Favorable Perception, Tech Savviness, and Environment Friendliness are considered as endogenous in the model, an assumption that is consistent with the literature to date (Rahimi, Azimi, & Jin, 2020).

The results of the two-group estimation show that the effects of exogenous variables defining the endogenous variables are different among men and women. Among men, being Hispanic influenced Environment Friendliness, while this relationship was not significant among women. For shared ridehailing services, age 61 and above had a negative impact for men, while among women living in Tampa had a significant negative impact.

Gendered differences were also observed in the relationships between exogenous variables and willingness to share rides in AVs. For women, preference towards being a driver significantly harmed willingness to use AV shared ridehailing, while that effect was not significant among men. On the male sample, being a commuter, or having conditions limiting their ability to drive were positive predictors of AV shared ridehailing usage. Having a condition limiting driving, however, was a negative predictor of willingness to share AVs among men. Income lower than \$25,000 was a positive predictor of AV shared ridehailing use for both men and women.

The one group solution considers gender as an additional exogenous variable. This approach to modeling does not offer much in understanding the differences among willingness to share AV rides among the different gender. However, some insights can be drawn from this exercise. Being a female did not significantly impact Environment Friendliness, nor shared ridehailing usage; suggesting that in the sample analyzed, those attributes were similarly measured for men and women. Being a woman did, however, negatively impact Tech Savviness, AV Favorable Perception, and Willingness to Share Rides in an AV.

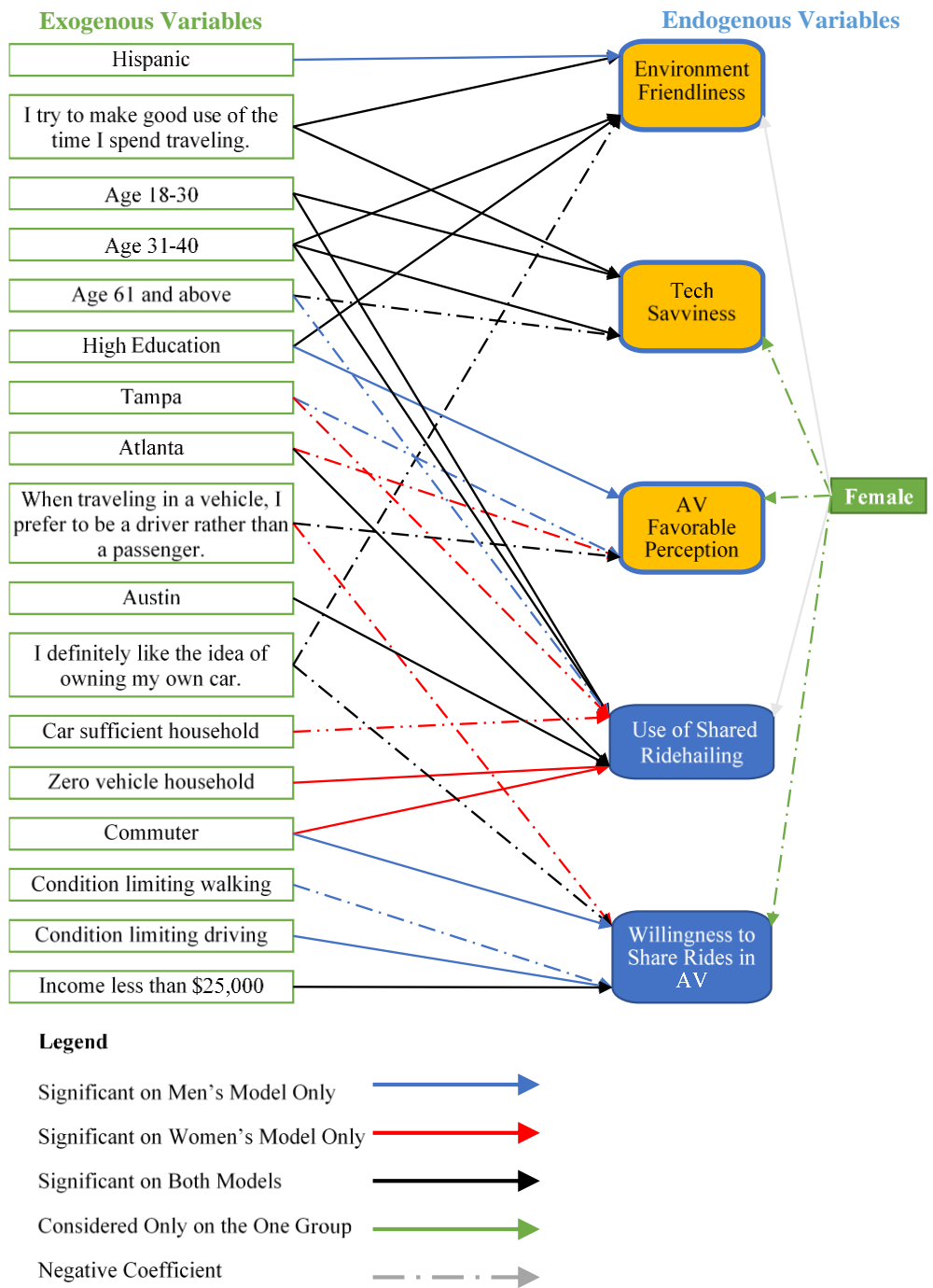
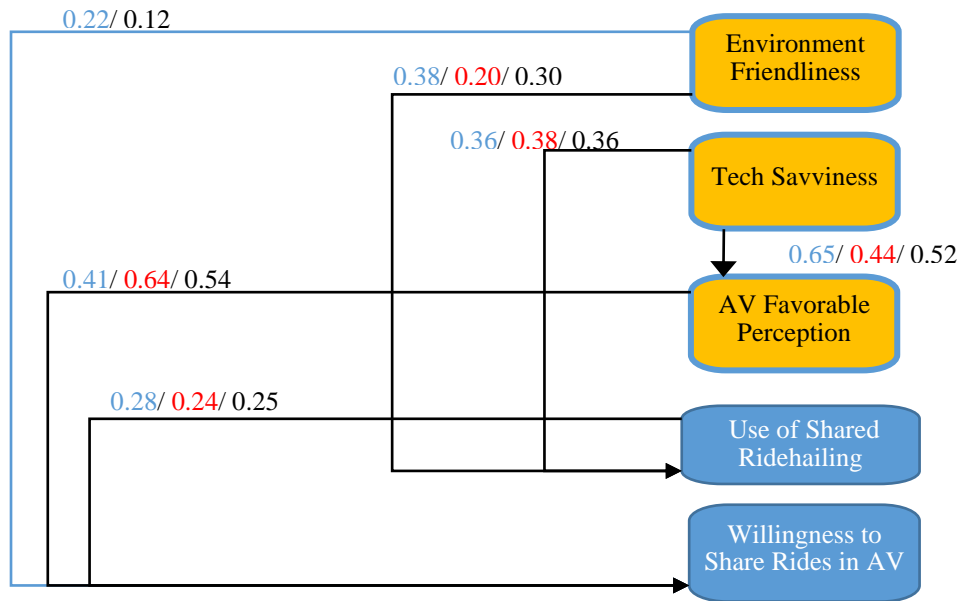

Figure 10 Illustration of the Relationships between Exogenous and Endogenous Variables on Willingness to Share Rides in Autonomous Vehicles Model

Figure 11 illustrates the unstandardized estimates for the relationships between endogenous variables for the two-group and one-group solutions. Similarly, Figure 11 Structural Relationship between Endogenous Variables on Willingness to Share AVs Model (Unstandardized)

shows the standardized estimates used on computing total and partial effects (Table 10).



Legend
 Significant on Men's Model Only Men's Coefficient/ One group →
 Significant on Both Models Men's Coefficient/ Women's Coefficient/ One group →

Figure 11 Structural Relationship between Endogenous Variables on Willingness to Share AVs Model (Unstandardized)

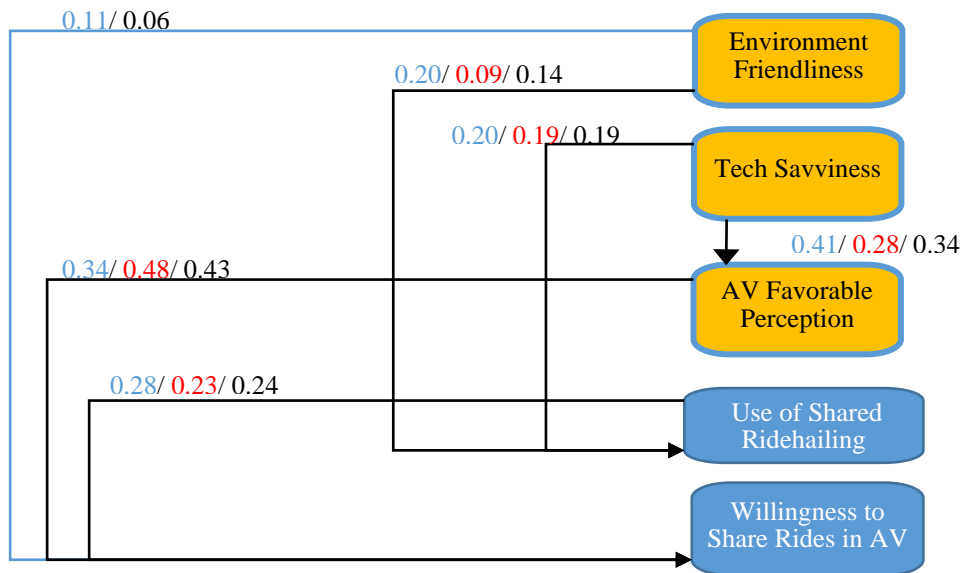

Legend
 Significant on Men's Model Only Men's Coefficient/ One group →
 Significant on Both Models Men's Coefficient/ Women's Coefficient/ One group →

Figure 12 Structural Relationship between Endogenous Variables on Willingness to Share AVs

Model (STDYX)

The relationships between the endogenous variables in the model are of great importance in understanding how willingness to share rides in autonomous ridehailing services are defined. To aid in understanding direct, indirect, and total effects, a table of total effects was calculated and is shown in Table 10. As it was observed in the previous chapter, Technology Savviness was an important predictor of AV Favorable Perception. Technology Savviness also positively influenced shared ridehailing use, however, the direct effect of Tech Savviness on Willingness to share AV ridehailing rides was not significant.

An important finding of this research is the different roles played by Environment Friendliness for men and women. Environment Friendliness had a positive impact on the usage of shared ridehailing, however, the estimated coefficient was twice as large for men as it was for women. When looking at the effect of Environment Friendliness on willingness to share AV ridehailing trips, that estimate was significant only for the male sample. In fact, the total effect of Environment Friendliness was 5 times larger for men than it was for women (Table 10). Rather, women’s willingness to share AV ridehailing was more strongly predicted by AV Favorable Perception. This finding suggests that, while men might be driven to pooled rides by its environmental benefits, women place a high value on trusting the technology. And even though women are more likely to use shared ridehailing services when a driver is present, uncertainties about the technology are driving women away from expressing interest in using the service when the vehicle is autonomous and the driver is no longer present.

Table 10 Total Effects Table for the Willingness to Share Rides in Autonomous Vehicles

	Women			Men			One group		
	Direct	Indirect	Total	Direct	Indirect	Total	Direct	Indirect	Total
Environment Friendliness	0.010	0.020	0.030	0.112	0.054	0.166	0.057	0.034	0.091
Tech Savviness		0.177	0.177		0.195	0.195		0.194	0.194
AV Favorable Perception	0.478		0.478	0.344		0.344	0.432		0.432
Shared ridehailing usage	0.226		0.226	0.277		0.277	0.241		0.241
Age 18-30		0.095	0.095		0.095	0.095		0.094	0.094
Age 31-40		0.049	0.049		0.080	0.080		0.060	0.060
Age 61+		-0.020	-0.020		-0.075	-0.075		-0.043	-0.043
Hispanic					0.012	0.012		0.003	0.003
High education		0.019	0.019		0.060	0.060		0.036	0.036
Commuter	0.031	0.027	0.058	0.067	0.011	0.078	0.048	0.023	0.071
Condition limiting walking	-0.028		-0.028	-0.064		-0.064	-0.041		-0.041
Condition limiting driving	-0.038		-0.038	0.075		0.075	0.011		0.011
Zero vehicle household		0.013	0.013		0.008	0.008		0.014	0.014
Car sufficient household		-0.014	-0.014		-0.012	-0.012		-0.015	-0.015
Tampa		-0.022	-0.022		-0.019	-0.019		-0.024	-0.024
Atlanta					0.017	0.017		0.009	0.009
Austin		0.046	0.046		0.051	0.051		0.048	0.048
Income less than \$25,000	0.058		0.058	0.059		0.059	0.051		0.051
Prefer to be a driver	-0.058	-0.066	-0.124	0.005	-0.047	-0.042	-0.034	-0.057	-0.091
Like the idea of owning a car	-0.109	-0.007	-0.116	-0.097	-0.025	-0.122	-0.101	-0.018	-0.119
Try to make good use of time spent traveling		0.064	0.064		0.101	0.101		0.082	0.082
Female							-0.069	-0.103	-0.172

Table 11 shows the goodness of fit statistics both for the two-group solution and for the one-group solution. Overall, both models fit the data well, however, based on the chi-square

different test (Asparouhov & Muthén, 2006), constraining the estimates for a single solution worsens the fit of the model to the data.

Table 11 *Goodness of Fit of Models Exploring Willingness to Use Shared Autonomous Ridehailing*

	Multi-group solution	One group solution
Sample size	N _{male} =1385, N _{female} =1939	3324
Number of free parameters	132	80
<i>Chi-square</i>		
Value	1783.7	1721.1
Degrees of freedom	580	290
Contribution from the male group	891.3	
Contribution from the female group	892.4	
Baseline model - Value	6930.3	7500.3
Baseline model - Degrees of freedom	658	343
Baseline model - P-value	0.000	0.000
Difference testing - Value	81.2	
Difference testing - Degrees of freedom	37	
Difference testing - P-value	0.000	
<i>RMSEA</i>		
Estimate	0.035	0.038
90% C.I.	0.033-0.037	0.036-0.040
Probability < 0.05	1.000	1.000
<i>Other measures</i>		
CFI	0.808	0.800
TLI	0.782	0.764
WRMR	2.323	2.224

Note. RMSEA = Root Mean Square Error of Approximation; 90% C.I.= 90% Confidence interval for RMSEA; CFI = Comparative Fit Index; TLI = Tucker-Lewis Index; WRMR = Weighted Mean Square Residual.

CONCLUSIONS AND POLICY IMPLICATIONS

In the T4 survey, women reported using shared ridehailing services, such as UberPOOL and Lyft Line, more often than men. However, they are significantly less willing to use those services if ridehailing providers shift to autonomous vehicles. Understanding the motivations behind this hesitancy is key to ensuring that, in the future, these services continue to attend to women's travel needs. This dissertation looks at the broader picture; first exploring all the other factors, beyond gender, that can influence one's decision to use autonomous shared ridehailing.

Willingness to ride in shared autonomous ridehailing services varied across different demographics groups. It decreased significantly with age, and increased for groups with higher levels of education, though not as consistently. Household characteristics did not seem to be as strongly related to the choice of using shared ridehailing services as personal characteristics. One important finding of the exploratory descriptive analysis is that important target groups of shared ridehailing services are still uncertain about their willingness to use shared AV ridehailing; increased neutrality was observed among individuals without driver's licenses and respondents living in car-deficient households when compared to their counterparts.

General attitudes and current behavior also mattered when deciding willingness to use AV ridehailing services. Those who agreed that they prefer living close to transit agreed to use AV shared services close to twice as often as those who either disagreed or were neutral to living close to transit. Current ridehailing users of both shared and private services reported being more interested in the AV versions of the service when compared to those who were not ridehailing users

at the time of the survey. Those who had taken a ride in an autonomous vehicle prior to the survey reported being willing to use them as a shared-ride service more than twice as often.

The decision tree analysis supported the idea that gender is an important predictor of willingness to share rides in autonomous vehicles. It identifies that the most important aspects in separating groups by their willingness to use shared ridehailing rides are preferences towards being a car owner and population density at the home block group. Furthermore, the most important sociodemographic aspect identified by the decision tree was gender - in fact, the only two end nodes predicting agreement to the statement "I will use AV ridehailing services with other passengers I don't know" are male-only nodes.

While the differences between men's and women's travel behavior exist, they do not stand out on the analysis of the weighted responses to the T4 survey. The most noteworthy difference relates to long-distance travel for business purposes; men reported to travel more for work, both by car and by plane. This consistency in travel behavior extends to ridehailing usage. Men and women use private ridehailing services similarly, although more women reported that, had the service not been available, they would have used the bus or not taken the trip altogether. On shared ridehailing, on the other hand, a larger share of women reported using the pooled ride option when compared to men. This fact highlights the importance of studying willingness to share rides in autonomous vehicles from a gendered perspective. If women are willing to use those services when a driver is present, it is necessary to understand the barriers in continuing to provide that transportation to them as the fleets become increasingly autonomous.

It is known that, as reported in the survey and observed in the literature, women feel more uncomfortable around unfamiliar people than men, be it the unfamiliar driver or the matched passengers. It is thus speculated that the pooled rides provide additional layers of safety; similarly to the seminal concept proposed by Jane Jacobs (1961), the additional "eyes on the ride" would promote an enhanced safety perception. Thus removing the driver changes the experience of shared ridehailing services entirely: the newly added stranger, previously a layer of security, now poses an additional threat that would not be there, had the service been private. Another way to look at the transition to an autonomous ridehailing fleet would be: in conventional rides, the driver acts as a mediator of the service provided, and as additional eyes him/herself, would protect passengers from one another. That layer of security is also gone with ride automation.

The model results from the two-group analysis corroborate the idea that the main barriers to women's adoption of autonomous shared ridehailing lie in the perception of the technology. The structural relationships between endogenous variables show that, while for men their willingness to share rides in an AV depends equally on their environment-friendliness and their perception of AVs, that is not the case for women. In the female model, environment-friendliness did not significantly predict willingness to use AV shared ridehailing, rather, that estimate relied solely on them having a favorable perception of autonomous vehicles. It is important to highlight here that, not only the latent construct Environment Friendliness was measured identically for men and women when considering them together, but gender was also not a significant predictor of environment friendliness.

The investigation of the gender differences on willingness to share AV ridehailing trips contributes to the literature by unraveling the underlying attitudinal motivators behind men's and women's interest in ridesharing. Such understanding can assist ridehailing service providers in shaping pooled ride services in a way that appeals equally to both men and women. Examples of such strategies can be designing personal security features on autonomous vehicles to ensure safety for all passengers when traveling with unfamiliar riders, and marketing campaigns that promote

trust in the technology.

In the future, it would be very interesting to understand how the perceptions analyzed in this study changed in a post-pandemic world. New concerns regarding being in close quarters with others, especially unfamiliar people, have arisen since this study was conducted. The long-lasting pandemic may have changed people's attitudes towards sharing in a rather significant way. On the other hand, pandemic-related measures to ensure physical distancing and safety against the coronavirus may encourage pooled rides, as they might provide an enhanced security perception as well. At the time of the writing, it is challenging to assess the extent to which the pandemic effects are still in play, however, moving forward it is fundamental for the future of shared ridehailing services to understand people's perceptions about pooled rides, as well as their intentions and expectations to use those services in the future.

REFERENCES

- Asgari, H., & Jin, X. (2019). Incorporating Attitudinal Factors to Examine Adoption of and Willingness to Pay for Autonomous Vehicles. *Transportation Research Record: Journal of the Transportation Research Board*, 2673(8), 418-429. doi:10.1177/0361198119839987
- Asparouhov, T., & Muthén, B. (2006). Robust Chi Square Difference Testing with Mean and Variance Adjusted Test Statistics. Mplus Web Notes: No. 10. Retrieved May 16, 2021, from <https://www.statmodel.com/download/webnotes/webnote10.pdf>
- Böcker, L., & Meelen, T. (2017). Sharing for People, Planet or Profit? Analysing Motivations for Intended Shared Economy Participation. *Environmental Innovation and Societal Transitions*, 23, 28-39. doi:10.1016/j.eist.2016.09.004
- Bansal, P., & Kockelman, K. (2018). Are We Ready to Embrace Connected And Self-Driving Vehicles? A Case Study of Texans. *Transportation*, 45(2), 641-675. doi:10.1007/s11116-016-9745-z
- Bansal, P., Kockelman, K. M., & Singh, A. (2016). Assessing Public Opinions of and Interest in New Vehicle Technologies: An Austin Perspective. *Transportation Research Part C: Emerging Technologies*, 67, 1-14. doi:10.1016/j.trc.2016.01.019
- Bansal, P., Kockelman, K., & Singh, A. (2016). Assessing Public Opinions of and Interest in New Vehicle Technologies: An Austin Perspective. *Transportation Research Part C: Emerging Technologies*, 67, pp. 1-14. doi:10.1016/j.trc.2016.01.019
- Beirão, G., & Sarsfield Cabral, J. (2008). Market Segmentation Analysis Using Attitudes Toward Transportation: Exploring the Differences Between Men and Women. *Transportation Research Record: Journal of the Transportation Research Board*, 2067, 56-64. doi:10.3141/2067-07
- Bennetts, S. K., Hokke, S., Crawford, S., Hackworth, N. J., Leach, L. S., Nguyen, C., . . . Cooklin, A. R. (2019). Using Paid and Free Facebook Methods to Recruit Australian Parents to an Online Survey: An Evaluation. *Journal of Medical Internet Research*, 21(3), e11206.
- Blumenberg, E. (2004). En-gendering Effective Planning: Spatial Mismatch, Low-Income Women, and Transportation Policy. *Journal of the American Planning Association*, 70(3), 269-281. doi:10.1080/01944360408976378
- Breiman, L., Friedman, J., Olshen, R., & Stone, C. (1984). *Classification and Regression Trees*. New York: Chapman & Hall/CRC.
- Broadbuss, A. (2019). Can Autonomous Vehicles Help Liberate Women? *6th International Conference on Women's Issues in Transportation (WLiT)*. Irvine, CA: 6th International Conference on Women's Issues in Transportation.

- Broaddus, A. (2019). Can Autonomous Vehicles Help Liberate Women? Irvine, CA: 6th International Conference on Women's Issues in Transportation.
- Built-in. (2021). *US Tech Hubs*. Retrieved July 31, 2021, from <https://builtin.com/tech-hubs>
- Byrne, B. M. (2012). *Structural Equation Modeling with Mplus: Basic Concepts, Applications, and Programming*. New York: Taylor & Francis Group, LLC.
- Capasso da Silva, D., & Rodrigues da Silva, A. N. (2020). Sustainable Modes and Violence: Perceived Safety and Exposure to Crimes on Trips to and From a Brazilian University Campus. *Journal of Transport and Health, 16*, 100817. doi:10.1016/j.jth.2019.100817
- Chana, H. J., Ishaq, R., & Shifan, Y. (2017). User Preferences Regarding Autonomous Vehicles. *Transportation Research Part C: Emerging Technologies, 78*, 37-49.
- Chauhan, R., Conway, M. W., Capasso da Silva, D., Salon, D., Shamshiripour, A., Rahimi, E., . . . Derrible, S. (2021). A Database of Travel-Related Behaviors and Attitudes Before, During, and After COVID-19 in the United States. *Nature Scientific Data*.
- Chee, P. N., Susilo, Y. O., Wong, Y. D., & Pernestål, A. (2020). Which Factors Affect Willingness to Pay for Automated Vehicle Services? Evidence from Public Road Deployment in Stockholm, Sweden. *European Transport Research Review, 12*, 20.
- Circella, G., A. F., Tiedeman, K., Berliner, R., Lee, Y., Fulton, L., . . . Handy, S. (2017). *What Affects Millennials' Mobility? PART II: The Impact of Residential Location, Individual Preferences and Lifestyles on Young Adults' Travel Behavior in California*. Retrieved March 17, 2021, from <https://escholarship.org/uc/item/5kc117kj>
- Circella, G., Alemi, F., Tiedeman, K., Handy, S., & Mokhtarian, P. (2018). *The Adoption of Shared Mobility in California and Its Relationship with Other Components of Travel Behavior*. Retrieved August 1, 2021, from <https://rosap.ntl.bts.gov/view/dot/35032>
- Circella, G., Fulton, L., Alemi, F., Berliner, R., Tiedeman, K., Mokhtarian, P., & Handy, S. (2016). *What Affects Millennials' Mobility? PART I: Investigating the Environmental Concerns, Lifestyles, Mobility-Related Attitudes and Adoption of Technology of Young Adults in California*. Retrieved March 17, 2021, from https://escholarship.org/content/qt6wm51523/qt6wm51523_noSplash_2c6e02b6985b0e28f86edadccdb33dc3.pdf?t=pnhnu0#:~:text=The%20result%20is%20the%20California,living%20arrangements%2C%20commuting%20and%20other
- Clifton, K., & Dill, J. (2005). *Conference on Research on Women's Issues in Transportation, Transportation Research Board Conference Proceedings* (Vol. 35). Chicago Illinois, United States. Retrieved August 13, 2020, from <https://trid.trb.org/view/773072>
- Conway, M., Mirtich, L., Salon, D., Harness, N., Ross, A., & Hong, S. (2021). Attitudes and transport choices: A critical review and Standardised Transport Attitude Measurement Protocol (STAMP). *In preparation*.
- Coppock, A., & McClellan, O. A. (2019). Validating the demographic, political, psychological, and experimental results obtained from a new source of online survey respondents. *Research & Politics, 6*(1), <https://doi.org/10.1177/2053168018822174>.
- Cornesse, C., & Bosnjak, M. (2018). Is there an association between survey characteristics and representativeness? A meta-analysis. *Survey Research Methods - Journal of the European Survey Research Association, 12*(1), 1-13.
- COVID Future. (2020). *COVID-19 and the Future Survey - How Will COVID-19 Change Our World?* Retrieved August 1, 2021, from <https://covidfuture.org/>
- Czajka, J., & Beyler, A. (2016). *Declining Response Rates in Federal Surveys: Trends and Implications (Background Paper)*. (Mathematica Policy Research) Retrieved August 1, 2021,

- from <https://mathematica.org/publications/declining-response-rates-in-federal-surveys-trends-and-implications-background-paper>
- Daniya, T., Geetha, M., & Suresh Kumar, K. (2020). Classification and Regression Trees with Gini Index. *Advances in Mathematics: Scientific Journal*, 9(10), 8237–8247. doi:10.37418/amsj.9.10.53
- Del Mar Alonso-Almeida, M. (2019). Carsharing: Another Gender Issue? Drivers of Carsharing Usage Among Women and Relationship to Perceived Value. *Travel Behaviour and Society*, 17, 36-45. doi:10.1016/j.tbs.2019.06.003
- Fürnkranz, J. (2011). Decision Tree. In S. C., & W. G.I. (Eds.), *Encyclopedia of Machine Learning*. Boston, MA: Springer. doi:10.1007/978-0-387-30164-8_204
- Franco, A., Malhotra, N., Simonovits, G., & Zigerell, L. (2017). Developing Standards for Post-Hoc Weighting in Population-Based Survey Experiments. *Journal of Experimental Political Science*, 4(2), 161-172.
- Freedman, D. A. (2006). On the So-Called ‘Huber Sandwich Estimator’ and ‘Robust Standard Errors. *The American Statistician*, 60(4), 299-302. Retrieved 08 2021, May, from www.jstor.org/stable/27643806
- Gkartzonikas, C., & Gkritza, K. (2019). What have we learned? A review of stated preference and choice studies on autonomous vehicles. *Transportation Research Part C: Emerging Technologies*, 98, 323-337.
- Gkartzonikas, C., & Gkritza, K. (2019). What Have We Learned? A Review of Stated Preference and Choice Studies on Autonomous Vehicles. *Transportation Research Part C: Emerging Technologies*, 98, 323-337. doi:10.1016/j.trc.2018.12.003
- Golob, T. (2003). Structural Equation Modeling for Travel Behavior Research. *Transportation Research Part B: Methodological*, 37(1), 1-25. doi:10.1016/S0191-2615(01)00046-7
- Haboucha, C., Ishaq, R., & Shiftan, Y. (2017). User Preferences Regarding Autonomous Vehicles. *Transportation Research Part C: Emerging Technologies*, 78, 37-49. doi:10.1016/j.trc.2017.01.010
- Hohenberger, C., Spörrle, M., & Welpel, I. (2016). How and Why Do Men and Women Differ in Their Willingness to Use Automated Cars? The Influence of Emotions Across Different Age Groups. *Transportation Research Part A: Policy and Practice*, 94, 374-385. doi:10.1016/j.tra.2016.09.022
- Howard, D., & Dai, D. (2014). Public Perceptions of Self-driving Cars: The Case of Berkeley, California. *93rd Annual Meeting of the Transportation Research Board*. Washington, D.C.: 93rd Annual Meeting of the Transportation Research Board.
- Hulse, L., Xie, H., & Galea, E. (2018). Perceptions of Autonomous Vehicles: Relationships with Road Users, Risk, Gender and Age. *Safety Science*, 102, 1-13. doi:10.1016/j.ssci.2017.10.001
- Hunt, J. D. (2001). Stated Preference Analysis of Sensitivities to Elements of Transportation and Urban Form. *Transportation Research Record: Journal of the Transportation Research Board*, 1780(1), 76-86.
- IBM Corp. (2017). IBM SPSS Decision Trees 25. Armonk, NY. Retrieved March 24, 2021, from http://public.dhe.ibm.com/software/analytics/spss/documentation/statistics/25.0/en/client/Manuals/IBM_SPSS_Decision_Trees.pdf
- IBM Corp. (2017). IBM SPSS Statistics Algorithms 25. Armonk, NY. Retrieved March 24, 2021, from http://public.dhe.ibm.com/software/analytics/spss/documentation/statistics/25.0/en/client/Manuals/IBM_SPSS_Statistics_Algorithms.pdf

- IBM Corp. (2017). IBM SPSS Statistics for Windows, Version 25.0. . Armonk, NY.
- Jacobs, J. (1961). *The Death and Life of Great American Cities*. New York: Random House Inc.
- JD Power. (2019). *Mobility Pipe Dreams? J.D. Power and SurveyMonkey Uncover Shaky Consumer Confidence About the Future*. Retrieved July 31, 2021, from <https://www.jdpower.com/business/press-releases/2019-q2-mobility-confidence-index-study-fueled-surveymonkey-audience>
- Jeremias, T. D., Narelle, H., Diaz-Lazaro, C. M., Poó, F. M., & Ledesma, R. D. (2021). Implicit and explicit attitudes in transportation research: A literature review. *Transportation Research Part F: Traffic Psychology and Behaviour*, 77, 87-101.
- Kalton, G., & Flores-Cervantes, I. (2003). Weighting methods. *Journal of Official Statistics*, 19(2), 81.
- Keusch, F. (2015). Why Do People Participate in Web Surveys? Applying Survey Participation Theory to Internet Survey Data Collection. *Management Review Quarterly*, 65(3), 183-216. doi:10.1007/s11301-014-0111-y
- Khoeini, S., Pendyala, R. M., Capasso da Silva, D., Lee, Y., Dias, F., Salon, D., . . . Maness, M. (2019). *Attitudes Towards Emerging Mobility Options and Technologies – Phase 2: Pilot and Full Survey Deployment*. Teaching Old Models New Tricks (TOMNET) Transportation Center.
- Kim, S., Circella, G., & Mokhtarian, P. (2019). Identifying Latent Mode-Use Propensity Segments in an All-AV Era. *99th Annual Meeting of the Transportation Research Board*. Washington, D.C.: 98th Annual Meeting of the Transportation Research Board.
- Kingsford, C., & Salzberg, S. (2008). What are Decision Trees? *Nature Biotechnology*, 26, 1011–1013. doi:10.1038/nbt0908-1011
- Kline, R. (2016). *Principles and Practice of Structural Equation Modeling* (4th ed.). New York, NY: The Guilford Press.
- Klinger, T., & Lanzendorf, M. (2015). Moving between Mobility Cultures: What Affects the Travel Behavior of New Residents? *Transportation*, 43, 243-271. doi:10.1007/s11116-014-9574-x
- Konduri, K., You, D., Garikapati, V., & Pendyala, R. M. (2016). Enhanced Synthetic Population Generator that Accommodates Control Variables at Multiple Geographic Resolutions. *Transportation Research Record, The Journal of the Transportation Research Board*, 2563(1), 40-50. doi:10.3141/2563-08
- Kroesen, M., Handy, S., & Chorus, C. (2017). Do Attitudes Cause Behavior or Vice Versa? An Alternative Conceptualization of the Attitude-Behavior Relationship in Travel Behavior Modeling. *Transportation Research Part A: Policy and Practice*, 101, 190-202. doi:10.1016/j.tra.2017.05.013
- Krueger, R., Rashidi, T., & Rose, J. (2016). Preferences for Shared Autonomous Vehicles. *Transportation Research Part C: Emerging Technologies*, 69, 343-355. doi:10.1016/j.trc.2016.06.015
- Laidlaw, K., & Sweet, M. (2018). Estimating Consumer Interest in Private Ownership and Shared Use of Autonomous Vehicles in the Greater Toronto-Hamilton Area. Washington, D.C.: 97th Annual Meeting of the Transportation Research Board.
- Lavieri, P., & Bhat, C. (2019). Modeling Individuals' Willingness to Share Trips with Strangers in an Autonomous Vehicle. *Transportation Research Part A: Policy and Practice*, 124, 242-261. doi:10.1016/j.tra.2019.03.009
- Lavieri, P., Garikapati, V., Bhat, C., Pendyala, R. M., Astroza, S., & Dias, F. (2017). Modeling Individual Preferences for Ownership and Sharing of Autonomous Vehicle Technologies.

- Transportation Research Record: Journal of the Transportation Research Board*, 2665(1), 1-10. doi:10.3141/2665-01
- Lee, J., Lee, D., Park, Y., Lee, S., & Ha, T. (2019). Autonomous Vehicles Can Be Shared, But a Feeling of Ownership Is Important: Examination of the Influential Factors for Intention to Use Autonomous Vehicles. *Transportation Research Part C: Emerging Technologies*, 107, 411-422. doi:10.1016/j.trc.2019.08.020
- Lee, Y.-C., & Mirman, J. (2018). Parents' Perspectives on Using Autonomous Vehicles to Enhance Children's Mobility. *Transportation Research Part C: Emerging Technologies*, 96, 415-431. doi:10.1016/j.trc.2018.10.001
- Lippke, K., & Noyce, C. (2020). Public Acceptance and Adoption of Shared-Ride Services in the Ride-Hailing Industry. Master Thesis presented to the University of Michigan. Retrieved May 16, 2021, from <https://deepblue.lib.umich.edu/bitstream/handle/2027.42/154994/Public%20Acceptance%20and%20adoption%20of%20shared%20ride%20services.pdf?sequence=1>
- Liu, P., Guo, Q., Ren, F., Wang, L., & Xu, Z. (2019). Willingness to Pay for Self-Driving Vehicles: Influences of Demographic and Psychological Factors. *Transportation Research Part C: Emerging Technologies*, 100, 306-317. doi:10.1016/j.trc.2019.01.022
- Loo, B. P. (2002). Role of Stated Preference Methods in Planning for Sustainable Urban Transportation: State of Practice and Future Prospects. *Journal of Urban Planning and Development*, 128(4).
- Maciejewska, M., Marquet, O., & Miralles-Guasch, C. (2019). Changes in Gendered Mobility Patterns in the Context of the Great Recession (2007-2012). *Journal of Transport Geography*, 79, 102478. doi:10.1016/j.jtrangeo.2019.102478
- Manca, S., & Fornara, F. (2019). Attitude Toward Sustainable Transport as a Function of Source and Argument Reliability and Anticipated Emotions. *Sustainability*, 11. doi:10.3390/su11123288
- MARG. (2016). *PopGen: Synthetic Population Generator [online]*. Mobility Analytics Research Group. Retrieved March 6, 2021, from Mobility Analytics Research Group: <http://www.mobilityanalytics.org/popgen.html>
- Menon, N. (2015). *Consumer Perception and Anticipated Adoption of Autonomous Vehicle Technology: Results from Multi-Population Surveys*. Tampa, FL: University of South Florida Graduate Theses and Dissertations. Retrieved March 17, 2021, from <https://scholarcommons.usf.edu/etd/5992>
- Menon, N. (2017). *Autonomous Vehicles: An Empirical Assessment of Consumers' Perceptions, Intended Adoption, and Impacts on Household Vehicle Ownership*. Tampa, FL: University of South Florida Graduate Theses and Dissertations. Retrieved March 17, 2021
- Miller, C. A., Guidry, J. P., Dahman, B., & Thomson, M. D. (2020). A Tale of Two Diverse Qualtrics Samples: Information for Online Survey Researchers. *Cancer Epidemiology, Biomarkers, and Prevention*, 29(4), 731-735.
- Montoro, L., Useche, S., Alonso, F., Lijarcio, I., Bosó-Seguí, P., & Martí-Belda, A. (2019). Perceived Safety and Attributed Value as Predictors of the Intention to Use Autonomous Vehicles: A National Study with Spanish Drivers. *Safety Science*, 120, 865-876. doi:10.1016/j.ssci.2019.07.041
- Muthén, B., du Toit, S., & Spisic, D. (1997). Robust Inference using Weighted Least Squares and Quadratic Estimating Equations in Latent Variable Modeling with Categorical and Continuous Outcomes. Unpublished Technical Report. Retrieved May 16, 2021, from

- https://www.statmodel.com/download/Article_075.pdf
- Muthén, L., & Muthén, B. (2017). Mplus User's Guide. *Eighth*. Los Angeles, CA. Retrieved July 21, 2020, from <https://www.statmodel.com/>
- Narayanan, S., Chaniotakis, E., & Antoniou, C. (2020). Shared Autonomous Vehicle Services: A Comprehensive Review. *Transportation Research Part C: Emerging Technologies*, *111*, 255-293. doi:10.1016/j.trc.2019.12.008
- Nazari, F., Noruzoliaee, M., & Mohammadian, A. (2018). Shared Versus Private Mobility: Modeling Public Interest in Autonomous Vehicles Accounting for Latent Attitudes. *Transportation Research Part C*, *97*, 456-477. doi:10.1016/j.trc.2018.11.005
- Nielsen, T., & Haustein, S. (2018). On Sceptics and Enthusiasts: What Are the Expectations towards Self-Driving Cars? *Transport Policy*, *66*, 49-55. doi:10.1016/j.tranpol.2018.03.004
- Pakusch, C., Stevens, G., Boden, A., & Bossauer, P. (2018). Unintended Effects of Autonomous Driving: A Study on Mobility Preferences in the Future. *Sustainability*, *10*(7), 2404. doi:10.3390/su10072404
- Panagiotopoulos, I., & Dimitrakopoulos, G. (2018). An Empirical Investigation on Consumers' Intentions Towards Autonomous Driving. *Transportation Research Part C: Emerging Technologies*, *95*, 773-784. doi:10.1016/j.trc.2018.08.013
- Peng, Y. (2020). The Ideological Divide in Public Perceptions of Self-Driving Cars. *Public Understanding of Science*, *29*(4), 436-451.
- Pettigrew, S., Dana, L., & Norman, R. (2019). Clusters of Potential Autonomous Vehicles Users According to Propensity to Use Individual versus Shared Vehicles. *Transport Policy*, *76*, 13-20. doi:10.1016/j.tranpol.2019.01.010
- Pettigrew, S., Worrall, C., Talati, Z., Fritschi, L., & Norman, R. (2019). Dimensions of Attitudes to Autonomous Vehicles. *Urban, Planning and Transport Research*, *7*(1), 19-33. doi:10.1080/21650020.2019.1604155
- Priya Uteng, T. (2019). Smart Mobilities: A Gendered Perspective. *Kart og Plan*, *112*(4), 258-281. doi:10.18261/issn.2535-6003-2019-04-03
- Puget Sound Regional Council. (2017). *Household Travel Survey Program*. Retrieved March 17, 2021, from <https://www.psrc.org/household-travel-survey-program>
- Rahimi, A., Azimi, G., & Jin, X. (2020). Examining Human Attitudes Toward Shared Mobility Options and Autonomous Vehicles. *Transportation Research Part F: Traffic Psychology and Behavior*, 133-154. doi:10.1016/j.trf.2020.05.001
- Randazzo, R. (2019). *One Year After Fatal Uber Crash: Who Was Really at Fault? Here's the Whole Story*. Retrieved May 08, 2021, from <https://www.azcentral.com/story/news/local/tempe/2019/03/17/one-year-after-self-driving-uber-rafaela-vasquez-behind-wheel-crash-death-elaine-herzberg-tempe/1296676002/>
- Richardson, A. J., Ampt, E. S., & Meyburg, A. H. (1995). *Survey Methods for Transport Planning*. Melbourne: Eucalyptus Press.
- Ruggles, S., Flood, S., Goeken, R., Grover, J., Meyer, E., Pacas, J., & Sobek, M. (2020). IPUMS USA: Version 10.0 [dataset]. Minneapolis, MN. doi:10.18128/D010.V10.0
- Saeed, T. U., Burris, M. W., Labi, S., & Sinha, K. C. (2020). An Empirical Discourse on Forecasting the Use of Autonomous Vehicles Using Consumers' Preferences. *Technological Forecasting and Social Change*, *158*, 120130.
- Sanbonmatsu, D., Strayer, D., Yu, Z., Biondi, F., & Cooper, J. (2018). Cognitive Underpinnings of Beliefs and Confidence in Beliefs about Fully Automated Vehicles. *Transportation Research Part F: Traffic Psychology and Behaviour*, *55*, 114-122. doi:10.1016/j.trf.2018.02.029

- Sangho, C., & Mokhtarian, P. L. (2004). What type of vehicle do people drive? The role of attitude and lifestyle in influencing vehicle type choice. *Transportation Research Part A: Policy and Practice*, 38(3), 201-222.
- Sax, L., Gilmartin, S., & Bryant, A. (2003). Assessing Response Rate and Nonresponse Bias in Web and Paper Surveys. *Research in Higher Education*, 44(4), 409-432. Retrieved March 22, 2021, from www.jstor.org/stable/40197313
- Schoettle, B., & Sivak, M. (2014). *A Survey of Public Opinion about Autonomous and Self-Driving Vehicles in the U.S., the U.K., and Australia*. The University of Michigan Transportation Research Institute. Retrieved September 7, 2020, from <https://deepblue.lib.umich.edu/bitstream/handle/2027.42/108384/103024.pdf?sequence=1&disAllowed=y>
- Schoettle, B., & Sivak, M. (2014). Public Opinion about Self-Driving Vehicles in China, India, Japan, the U.S., the U.K., and Australia. Retrieved March 17, 2021, from <http://hdl.handle.net/2027.42/109433>
- Sener, I., & Zmud, J. (2019). Chipping Away at Uncertainty: Behavioral Responses to Self-Driving Vehicles and the Role of Ride-Hailing. *Transportation Planning and Technology*, 42(7), 645-661. doi:10.1080/03081060.2019.1650423
- Siddiqi, Z. (2012). Dynamic Ridesharing: Understanding the Role of Gender and Technology. Master's Thesis presented to the University of Toronto. Retrieved May 16, 2021, from https://tspace.library.utoronto.ca/bitstream/1807/33529/11/Siddiqi_Zarar_201211_MSc_thesis.pdf
- Siripanich, S. (2018). *Travel with Trust: Designing for Women's Safety in Autonomous Rideshares*. Retrieved November 13, 2019, from Teague Labs: <https://medium.com/teague-labs/travel-with-trust-designing-for-womens-safety-in-autonomous-rideshares-7baf959b02de>
- Smith, A. (2016). On-demand: Ride-hailing Apps. *Shared, Collaborative, and on Demand: The New Digital Economy*. Pew Research Center. Retrieved May 16, 2021, from <https://www.pewresearch.org/internet/2016/05/19/on-demand-ride-hailing-apps/>
- Sperling, D. (2018). *Three Revolutions: Steering Automated, Shared, and Electric Vehicles to a Better Future*. Island Press.
- Stark, J., & Meschik, M. (2018). Women's Everyday Mobility: Frightening Situations and their Impacts on Travel Behavior. *Transportation Research Part F: Traffic Psychology and Behavior*, 54, 311-323. doi:10.1016/j.trf.2018.02.017
- Sunkanapalli, S., Pendyala, R. M., & Kuppam, A. R. (2000). Dynamic Analysis of Traveler Attitudes and Perceptions Using Panel Data. *Transportation Research Record: Journal of the Transportation Research Board*, 1718(1), 52-60.
- TOMNET. (2020). *TOMNET Transformative Transportation Technologies (T4) Survey*. Retrieved April 23, 2021, from <https://tomnet-utc.engineering.asu.edu/t4-survey/>
- TOMNET UTC. (2020). *TOMNET Transformative Transportation Technologies (T4) Survey*. Retrieved August 1, 2021, from <https://tomnet-utc.engineering.asu.edu/t4-survey/>
- Van Acker, V., Mokhtarian, P., & Witlox, F. (2011). Going soft: on how Subjective Variables Explain Modal Choices for Leisure Travel. *European Journal of Transport and Infrastructure Research*, 11(2). doi:10.18757/ejtir.2011.11.2.2919
- Van Acker, V., Van Wee, B., & Witlox, F. (2010). When Transport Geography Meets Social Psychology: Toward a Conceptual Model of Travel Behavior. *Transport Reviews*, 30(2), 219-240. doi:10.1080/01441640902943453
- Winter, K., Cats, O., Martens, K., & Van Arem, B. (2017). A Stated-Choice Experiment on Mode

- Choice in an Era of Free-Floating Carsharing and Shared Autonomous Vehicles. Washington, D.C.: 96th Annual Meeting of the Transportation Research Board.
- Wu, J., Liao, H., & Wang, J.-W. (2020). Analysis of consumer attitudes towards autonomous, connected, and electric vehicles: A survey in China. *Research in Transportation Economics*, 80, 100828.
- Ye, X., Konduri, K., Pendyala, R. M., Sana, B., & Waddell, P. (2009). A Methodology to Match Distributions of Both Household and Person Attributes in the Generation of Synthetic Populations. Washington, DC: 88th Annual Meeting of the Transportation Research Board.